

5T202212



2023



Midea Building Technologies Division
Midea Group

Add.: Midea Headquarters Building, 6 Midea Avenue, Shunde, Foshan, Guangdong, China

Postal code: 528311

mbt.midea.com www.midea-group.com

Midea reserves the right to change the specifications of the product, and to withdraw or replace products without prior notification or public announcement. Midea is constantly developing and improving its products.



Energy-efficient



On-stop service



Multiple functions

Midea AHU

MAKE A BEAUTIFUL TOMORROW

Midea MBT

Midea MBT(Midea Building Technologies) is a key division of the Midea Group, a leading provider of comprehensive solutions of intelligent building, involving energy sources, elevators, control systems, and heating, ventilation & air conditioning. Midea MBT has continued with the tradition of innovation upon which it was founded and emerged as a global leader in the HVAC and building management industry. A strong drive for advancement has resulted in an extensive R&D department that has placed Midea MBT at the forefront of a competitive -edge. Through these independent projects and joint-cooperation with other global enterprises, Midea has supplied thousands of innovative solutions to customers worldwide.

Several production bases are situated on Shunde, Chongqing, Hefei, and Italy.

MBT Shunde: 38 product lines focusing on VRF, Split Products, Heat Pump Water Heaters and AHU/FCU.

MBT Chongqing: 14 product lines focusing on Water Cooled Centrifugal/Screw/Scroll Chillers, Air Cooled Screw/Scroll Chillers and AHU/FCU.

MBT Hefei: 11 product lines focusing on VRF, Chillers and Heat Pump Water Heaters.

Clivet S.p.A: 50,000m2 workshop in Feltre and Verona, covering products such as ELFO system, hydronic, WHLP, packaged, split and close control and so on.



MBT Learning Academy



Objective

MBT Learning Academy aims to provide training to the sales personnel as well as technical personnel in order to increase the utilization for your MBT equipment. Once you have purchased equipment from MBT, taking care of the equipment is topmost priority. MBT Learning Academy offers training courses to learn firsthand from the manufacturer what it takes to get the best out of your MBT product. The goal of MBT Learning Academy is to provide product specific training, safe work procedures and expertise in carrying out the installation and maintenance of MBT products as well as teaching the main selling points in order to help the sales people sell the MBT products with ease.

Training Centers

Our world class training centers provide knowledge and skills necessary to efficiently deploy MBT technologies. The training centers include dedicated laboratories to provide hands-on experiences with various systems, components and controls to refresh and enhance the skills of your sales, design and installation and service teams. Right now we operate our trainings from the below two locations:

1. MBT Training Center

Address: MBT Training Center, 2nd Floor, Building 6, Midea Global Innovation Center, Beijiao, Shunde, Foshan, China Pin-528311

The Midea MBT Training Center is situated 70 kilometers from Baiyun Guangzhou International Airport.

Products: VRF, M thermal

2. Chongqing Midea Training Center

Address: No. 15, Qiangwei Road, Nan'an District, Chongqing, China

Chongqing Midea Training Center is 35 kilometers from Chongqing International Airport.

Products: Centrifugal Chiller, Screw/Scroll Chiller and Terminals



VRF training



M thermal training



Chiller training

Global Technical Trainings

The training courses by MBT Learning Academy are divided into the following two categories with different targeted audiences for each.

Design and Application Trainings: The design and application trainings for various products are basically for the sales personnel selling MBT products in order to give them basic understanding about the main features. The trainings are conducted on a global level inviting sales engineers, technical engineers, consultants and project designers from different parts of the world.

After Sales- Service Trainings: These trainings are dedicated for the After Sales/ Service personnel in order for them to better carry out the installation, commissioning and maintenance of MBT products. Technical person and engineers from different parts of the world are invited to take part in these trainings.

Online Trainings: The trainings to the Global customers can also be done online with the help of Team and Midea Meeting software. This way, the customers do not need to be physically present for the training. Amid the COVID-19 pandemic, MBT Learning Academy has conducted a lot of online trainings. The training videos are available on the TSP system and can be downloaded by using QR codes.

Products: VRF, M thermal, Chillers and Terminals

Highly Skilled Trainers: The trainers for various courses by MBT Learning Academy are expert people with vast experiences in their field. Most of them have a deep insight about the global HVAC market and help the attendees to better understand the MBT products.

Training Certificates:

The attendees for Global trainings are provided a training certificate highlighting the courses discussed in the training, signed by Mr. Henry Cheng, General Manager of MBT Overseas Sales Company.

Registration:

You can contact your respective Midea contact point to provide you with the complete schedule about the global technical trainings as well as how to register for these trainings.

For further enquiries about the Global Trainings conducted by MBT Learning Academy, please send email at the following email address: peeyush@midea.com



Chiller After Sales Courses



Chiller Introduction Courses

Midea Global Spare Parts Center

The global spare parts center provides high quality and fast spare parts supply. Midea online system (<https://tsp.midea.com>) can query and purchase spare parts with one click, further shortening the supply time of spare parts.

The “**2** (HQ Spare parts center) + **10** (Regional Spare parts center) + **N** (Country Spare parts inventory)” Spare Parts Layout can ensure the timely supply of global after-sales spare parts.



Technical Support Platform (TSP)

TSP is a platform for customers to provide professional technical support. Through TSP, you can inquire product information, documentation, spare parts and troubleshooting, initiate technical questions and quality complaint process, and also support self-service spare parts order.

Website address: <https://tsp.midea.com/>

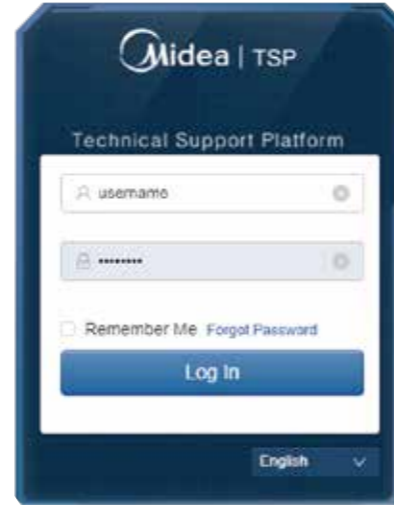

My order

Inquire spare parts from exploded view and place spare parts order directly in TSP.

Document inquiry and download

View or download product technical documentation online, such as catalogs, images, training PPTs, etc.

Technical inquiry & FAQ

Initiate technical questions online, and our technicians answer them online in time. Find a quick solution in the FAQ.

Troubleshooting

Query the error code and solution by SN, model name, error code or product type.

Complain

Initiate the product quality complaint process online, and our after-sales engineers handle related complaints in time.

Mobile Intelligence Service App (MISA)

MISA is the mobile terminal of TSP, with the same functions as TSP. The mobile service makes technical support more timely and convenient.

<https://link.midea.com>



FAQ



Complain



Technical Enquiry



Trouble shooting

Download

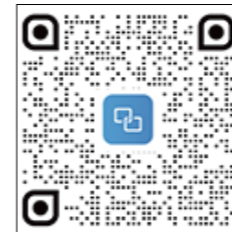

Scan above to download the mobile app

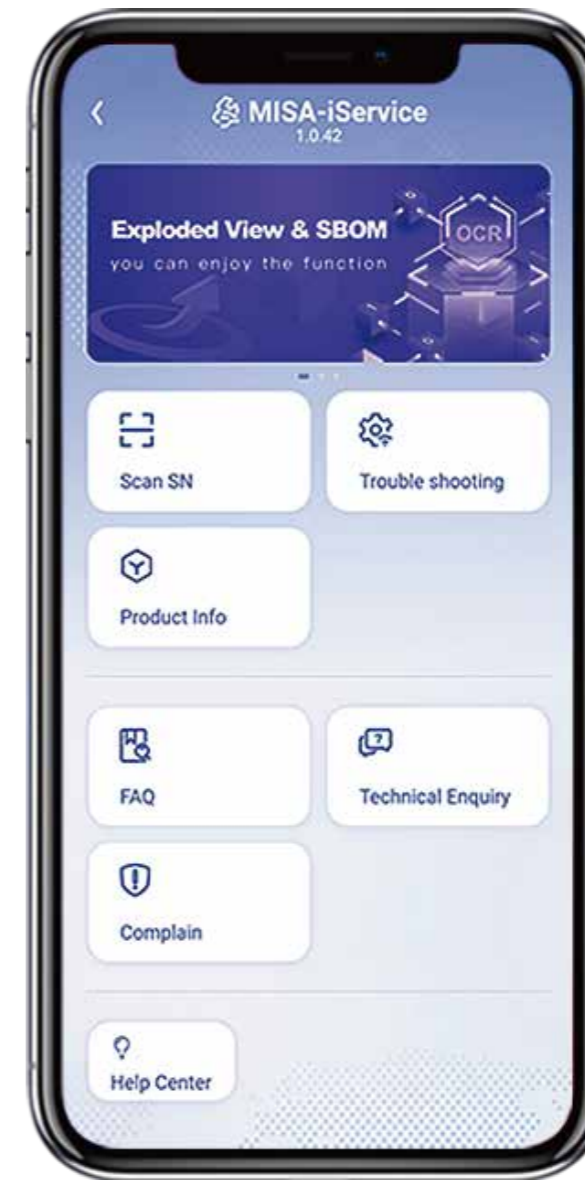

Search product manuals



Spare Parts list

Feedback



Thank you very much for your attention and advice

Contents

Overview	11
Nomenclature	12
Features	13
Categories	14
Specifications	15
Dimensions and Weight	19
Fan Motor Power	35
Humidification Performance and Specifications	43
Selection software	44
Unit installation	45
Electrical Wiring Diagram	48

Overview

Midea MKZS series AHU adopts Midea self-designed labyrinth type AHU as the prototype, and features low air leakage and high strength, and has no cold bridge. The unit can be classified into 12 combination types by section combination and structure. The enhanced structure allows for more convenient maintenance of filter and coil. The air flow ranges from 2000 m³/h to 50000 m³/h. Many static pressure options are available. The unit is compact and boasts excellent cooling and heating performance. Hot water coil and wet film humidifier can also be configured as required.



Orientation

Unit handling orientation is determined by location of pipe connection while facing the air outlet. The unit shown is left-handed connection unit, vice-versa will be is the right-handed connection unit.

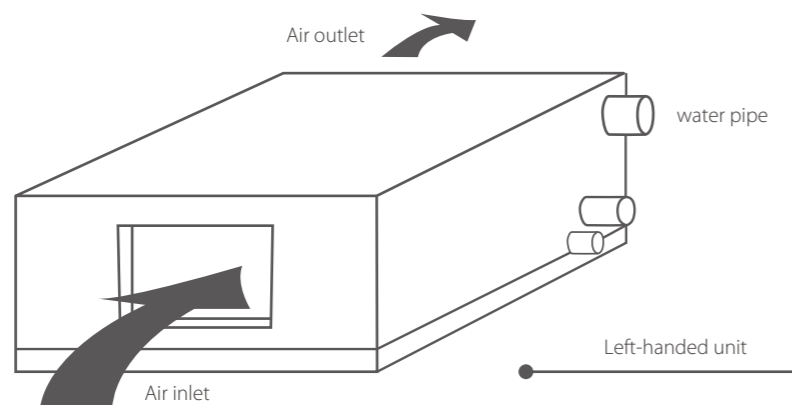

Nomenclature

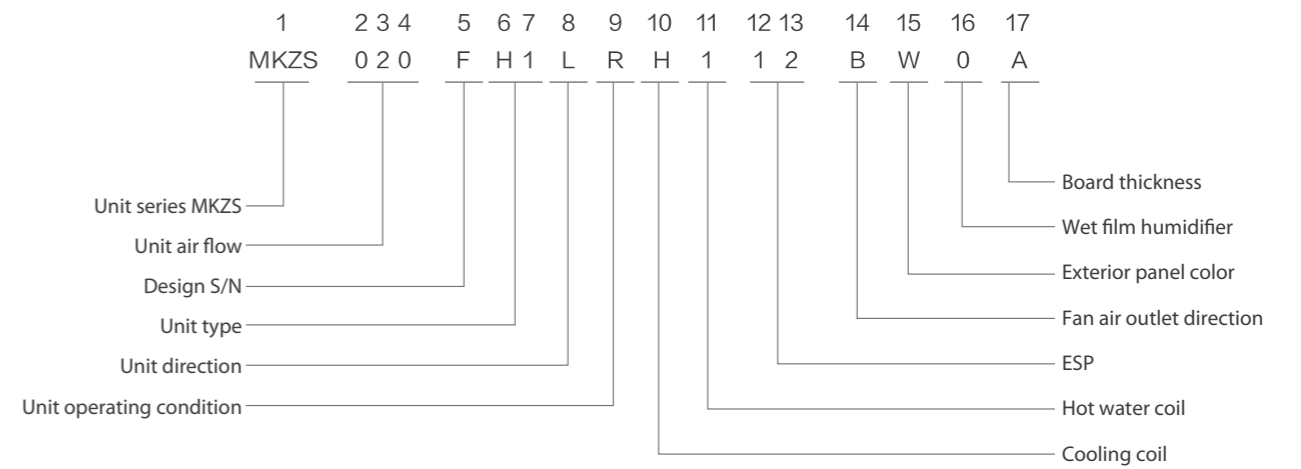

- 1**
Unit series: Midea AHU
- 2, 3, 4**
Unit air flow: *100m³/h
- 5**
Design S/N
- 6, 7**
Unit type:
H1~H9、 HA ; Horizontal standard I~Horizontal standard X;
V1~V3; Vertical Standard I~Vertical Standard III ;
(When the horizontal standard is used for ceiling units, the 6th code is changed to "c")
- 8**
Unit direction:
L - Left type; R - Right type
- 9**
Unit operating condition:
R - Air return; F - Fresh air; N - No cooling coil
- 10**
Cooling coil:
S - Standard cooling capacity; H - High cooling capacity; N - Not supported
- 11**
Hot water coil
1 - 1 row; 2 - 2 rows; N - Not supported
- 12, 13**
ESP: *10Pa
- 14**
Fan air outlet direction (standard: UF)
T - FT; R - UR; F - UF; B - FB
Horizontal units can be selected for air direction
- 15**
Exterior panel color: W - White (standard)
- 16**
Wet film humidifier:
0 - N/A; 1 - 50 mm thick; 2 - 100 mm thick; 3 - 150 mm thick; 4 - 200 mm thick
- 17**
Board thickness:
A - 25 mm thick; C - 50 mm thick

Fan direction

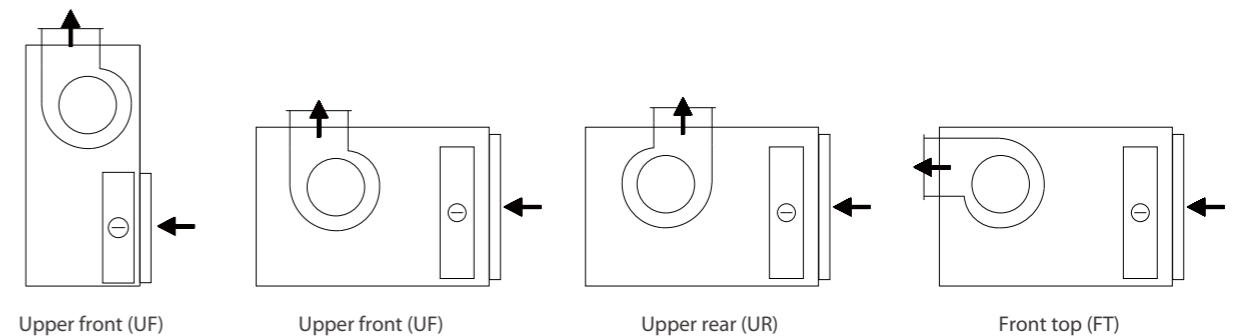

Features

Independent and innovative technology

The integrated panel through foam molding is equipped with aluminium frames (with grooves). During installation, a labyrinth type sealed structure similar to the tenon type can be formed. Connection of bolts and embedded nuts can ensure strong torque resistance. The cabinet mechanical strength can reach AHRI1350 CD4. The air leakage can reach AHRI1350 CL2.

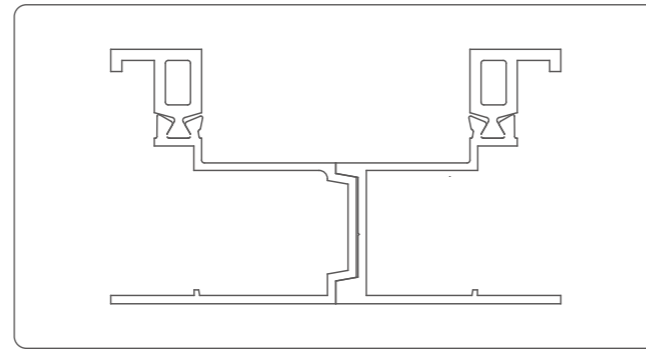

No cold bridge, not easy to corrode

High-pressure polyurethane inside the cabinet and specially designed sealing rubber can completely isolate the unit interior and the outside. This can prevent cold bridge. The cold bridge factor can reach AHRI1350 CB2. The external sheet metal is enclosed by aluminium frames to isolate the edges of sheet metal from wet air, thus avoiding rusting to the maximum extent possible.

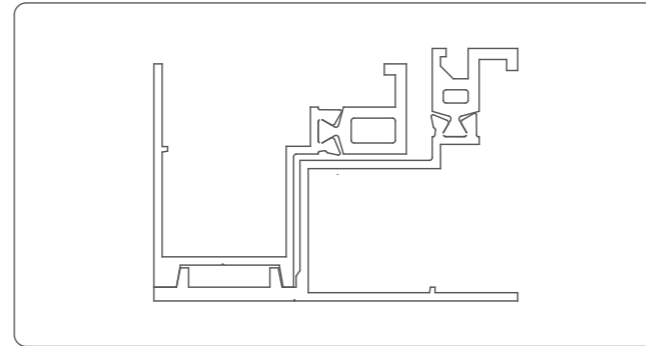

International professional certification



AHRI1350 Z Performance Rating		
Cabinet strength		CD4
Air leakage		CL2
Heat transfer coefficient	Air leakage considered	CT2
	Air leakage not considered	CT2
Cold bridge factor		BC2

Professional selection software, efficient heat exchanger

The heat exchanger is designed with the AHRI certified professional selection software. This ensures consistency between the selection parameters and the performance of the actual product. Requirements for various operating conditions can be met. The coil is made from RoHS certified copper pipes and aluminum fins, which are integrated through the cutting-edge mechanical expansion process. All coils have undergone airtightness test before delivery to ensure zero leakage.



Excellent insulation performance

The panel is made from polyurethane with low thermal conductivity and internal and external sheet metals through foam molding. The foam density is at least 50 kg/m³, allowing the panel to present good insulation and noise and vibration control. The insulation performance reaches AHRI1350 CT2.

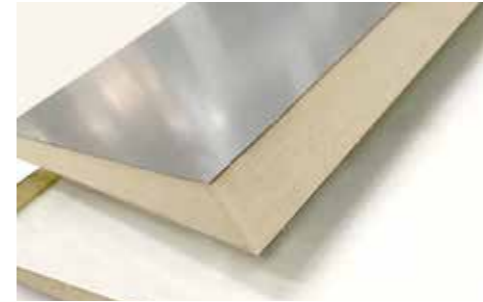

Customization

A total of 23 models with the air flow ranging from 2000 CMH to 50000 CMH are available. Up to 12 standard combinations are supported. There are many external static pressure options, and the unit wall thickness can be either 25 mm or 50 mm. The product supports cooling, heating, filtering, humidification, and many other functions. Various optional accessories can be selected for customized configuration to meet different requirements.



Multiple purification solutions

Plate type filter and bag type filter with different filtration grades are available to meet various requirements. For horizontal type standard units III, V, and IX, high and medium efficiency bag type filter with antibacterial feature is optional. Horizontal type standard unit VI adopts the advanced electrostatic dedusting and sterilization technology, and can be used to resolve the air pollution issue in public places such as metros and airports.



Smart integrated control

Mechatronic control achieves integrated control of fan motor and water valve. The control system consists of low voltage apparatus and thermostat of renowned brands. If the thermostat with communication feature is configured, remote control of the system can be implemented by connecting the system to a third-party control system (such as building automation). The control panel supports multiple protection mechanism such as misphase/phase loss of power supply, and over current, to ensure stable operation of the unit. Many external interlock mechanisms (fire damper, fresh air valve, switch-type water valve control signal, etc.) are also reserved. Integrated control can guarantee comfortable indoor temperature with energy efficiency.



Vertical type standard unit I

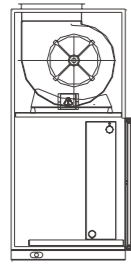

External nylon filter + Cooling coil + Fan

Vertical type standard unit II

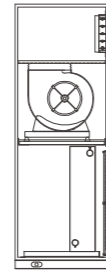

Return air louver + Cooling coil + Fan + Air outlet grille

Vertical type standard unit III

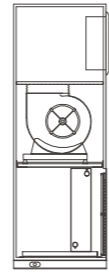

Return air louver + Cooling coil + Fan + Jet nozzle

Horizontal type standard unit I

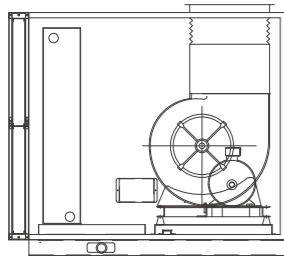

External nylon filter + Cooling coil + Fan

Horizontal type standard unit II

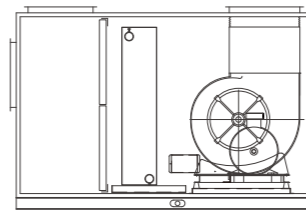

Mixing box + Primary efficiency filter + Cooling coil + Fan

Horizontal type standard unit III

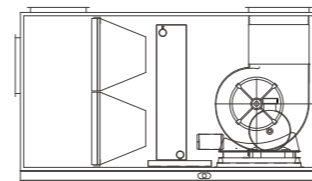

Mixing box + Primary efficiency filter + Medium efficiency filter + Cooling coil + Fan

Horizontal type standard unit IV

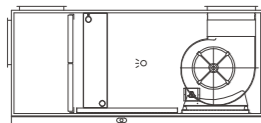

Mixing box + Primary efficiency filter + Cooling coil + Dry steam humidifier + Fan

Horizontal type standard unit V

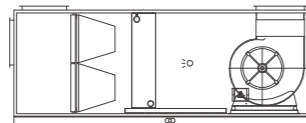

Mixing box + Primary efficiency filter + Medium efficiency filter + Cooling coil + Dry steam humidifier + Fan

Horizontal type standard unit VI

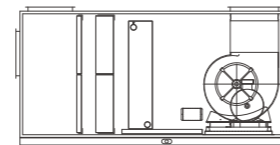

Mixing box + All-in-one plate type electrostatic filter + Cooling coil + Fan

Horizontal type standard unit VIII

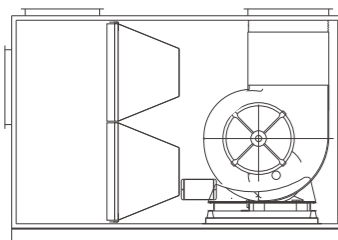

Mixing box + Primary efficiency filter + Medium efficiency filter + Fan

Horizontal type standard unit IX

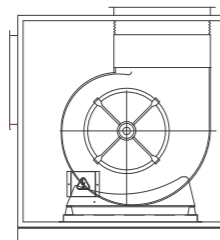

Air inlet + Fan

- Notes: 1. Vertical type standard unit I (V1), Horizontal type standard unit I (H1), and Horizontal type standard unit VIII (H8) come with the nylon filter, which can be replaced with the plate type filter as required.
 2. Evaporative humidifier can be configured (optional) after the Cooling coil section.
 3. Horizontal units can be customized with hot water coils, steam coils and water baffles (except horizontal standard IX and horizontal standard X)
 4. For standard configuration, G3 plate type primary filter and M5 bag type medium efficiency filter are provided.

Standard condition

Model	Air flow	Standard cooling capacity						High cooling capacity					
		Rate cooling capacity	Rated heating capacity	Water flow rate	Water resistance	Chilled water pipe diameter	Condensation water pipe diameter	Rate cooling capacity	Rated heating capacity	Water flow rate	Water resistance	Chilled water pipe diameter	Condensation water pipe diameter
MKZS	m ³ /h	kW	kW	L/s	kPa	DN	DN	kW	kW	L/s	kPa	DN	DN
020	2000	11.0	22.8	0.5	19.3	32	25	14.8	27.6	0.7	78.6	32	25
030	3000	17.2	35.1	0.8	46.0	32	25	22.7	41.9	1.1	28.8	32	25
040	4000	23.4	47.1	1.1	76.6	32	25	29.6	54.6	1.4	45.6	32	25
050	5000	28.2	57.0	1.3	28.2	32	25	34.5	64.5	1.6	56.1	32	25
060	6000	35.1	69.1	1.7	50.6	32	25	42.4	78.2	2.0	63.3	32	25
070	7000	41.0	80.7	2.0	48.7	40	25	48.8	92.5	2.3	31.1	40	25
080	8000	48.2	93.7	2.3	70.1	40	25	57.2	106.7	2.7	44.6	40	25
100	10000	59.7	115.7	2.8	71.6	40	25	74.2	138.1	3.5	45.4	50	25
120	12000	69.8	136.8	3.3	28.4	40	25	89.9	165.3	4.3	78.3	50	25
150	15000	90.4	172.7	4.3	46.0	50	32	115.0	207.6	5.5	22.6	50	32
180	18000	107.0	210.8	5.1	66.0	50	32	136.4	247.2	6.5	32.5	65	32
210	21000	126.6	247.3	6.0	79.3	65	32	157.4	289.4	7.5	38.9	65	32
240	24000	148.8	285.6	7.1	27.3	65	32	181.9	332.2	8.7	57.8	65	32
270	27000	167.5	321.3	8.0	30.0	65	32	204.7	372.0	9.8	61.4	65	32
300	30000	186.1	357.0	8.9	29.2	65	32	226.1	413.4	10.8	58.4	65	32
330	33000	204.7	392.7	9.8	37.9	80	32	253.0	456.8	12.1	73.6	80	32
350	35000	220.1	416.5	10.5	44.2	80	32	271.3	486.9	12.9	78.9	80	32
400	40000	230.8	451.0	11.0	78.2	80	32	299.8	546.1	14.3	55.4	80	32
450	45000	248.1	484.8	11.8	71.8	80	32	341.1	617.2	16.3	58.7	80	32
500	50000	275.6	538.5	13.1	77.9	80	32	379.0	685.9	18.1	57.7	80	32

- Notes: 1. Cooling: Air inlet DB/WB temperature is 27°C/19.5°C; water inlet/outlet temperature is 7°C/12°C.
 Heating: Air inlet DB temperature is 15°C; hot water inlet temperature is 60°C; water flow is the same as that in cooling condition.
 2. For actual use, if the fresh air flow increases, the unit cooling capacity will change. For details, please contact Midea.
 3. For parameters of units with the number of coil rows and air inlet conditions not listed in this table, refer to relevant model selection software.

Mdel	Air flow	Standard cooling capacity						High cooling capacity					
		Rate cooling capacity	Rated heating capacity	Water flow rate	Water resistance	Chilled water pipe diameter	Condensation water pipe diameter	Rate cooling capacity	Rated heating capacity	Water flow rate	Water resistance	Chilled water pipe diameter	Condensation water pipe diameter
		kW	kW	L/s	kPa	DN	DN	kW	kW	L/s	kPa	DN	DN
MKZS	m ³ /h												
020	2000	27.4	30.7	1.3	39.9	32	25	33.7	34.2	1.6	77.4	32	25
030	3000	40.5	44.3	1.9	30.3	32	25	47.9	48.9	2.3	34.6	32	25
040	4000	54.7	58.8	2.6	52.1	40	25	63.8	67.0	3.0	54.8	40	25
050	5000	68.4	73.8	3.3	60.2	40	25	79.8	83.9	3.8	63.8	50	25
060	6000	81.0	85.0	3.9	29.4	50	25	97.9	100.5	4.7	73.5	50	25
070	7000	89.6	95.0	4.3	44.5	50	25	115.4	116.7	5.5	22.1	50	25
080	8000	101.7	108.6	4.9	64.1	50	25	127.7	134.5	6.1	31.7	65	25
100	10000	132.8	154.9	7.0	69.0	65	25	162.1	167.3	7.7	33.6	65	25
120	12000	157.9	175.3	7.5	29.1	65	25	193.6	196.5	9.2	57.1	65	25
150	15000	194.7	221.3	9.3	37.8	65	32	252.6	252.3	12.0	60.4	80	32
180	18000	230.5	257.6	11.0	52.9	80	32	293.6	296.1	13.1	71.5	80	32
210	21000	276.3	303.6	13.2	63.6	80	32	331.5	336.1	13.9	79.5	80	32
240	24000	319.9	348.8	15.2	64.6	80	32	*366.2	*380.6	*12.5	74.5	80	32
270	27000	359.9	389.7	17.1	68.9	80	32	*409.6	*428.2	*13.9	80.0	80	32
300	30000	384.1	420.5	18.3	71.3	80	32	*455.2	*473.6	*15.5	79.4	80	32
330	33000	445.7	482.0	21.2	79.5	80	32	*503.6	*523.3	*17.1	75.8	80	32
350	35000	454.3	490.5	21.6	78.3	80	32	*552.5	*578.3	*15.5	78.8	80	32
400	40000	477.1	525.2	22.7	76.3	80	32	*589.3	*622.5	*18.7	77.1	80	32
450	45000	536.7	594.2	25.6	78.6	80	32	*647.2	*679.6	*19.3	79.2	80	32
500	50000	605.1	663.9	28.8	56.1	80	32	*727.9	*774.6	*21.7	68.5	80	32

Notes: 1. Cooling: Air inlet DB/WB temperature is 35°C/28°C; water inlet/outlet temperature is 7°C/12°C.

Heating: Air inlet DB temperature is 7°C; hot water inlet temperature is 60°C; water flow is the same as that in cooling condition.

2. Items with * indicates that the difference between water inlet temperature and water outlet temperature is greater than 5°C to control the refrigerant water pipe pressure drop.

3. For parameters of units with the number of coil rows and air inlet conditions not listed in this table, refer to relevant model selection software.

Mdel	Air flow	1 rows				2 rows			
		Rate heating capacity	Water flow rate	Water resistance	Water pipe diameter	Rate heating capacity	Water flow rate	Water resistance	Water pipe diameter
MKZS	m ³ /h	kW	L/s	kPa	DN	kW	L/s	kPa	DN
020	2000	6.7	0.2	1.0	32	13.6	0.3	5.3	32
030	3000	10.2	0.3	2.0	32	20.0	0.5	10.6	32
040	4000	13.8	0.3	3.0	32	27.2	0.6	16.0	32
050	5000	18.5	0.4	3.4	32	35.8	0.9	17.7	32
060	6000	23.2	0.6	5.5	32	43.7	1.0	28.0	32
070	7000	27.6	0.7	5.5	32	50.9	1.2	28.0	32
080	8000	32.5	0.8	7.9	32	56.8	1.4	40.4	32
100	10000	42.0	1.0	8.1	32	77.7	1.9	41.3	32
120	12000	48.7	1.2	13.8	32	88.8	2.1	8.4	32
150	15000	61.7	1.5	22.6	40	111.0	2.7	13.6	40
180	18000	75.2	1.8	31.0	40	135.3	3.2	18.6	40
210	21000	88.9	2.1	37.2	40	157.8	3.8	22.5	40
240	24000	103.1	2.5	54.1	40	174.7	4.2	32.0	40
270	27000	116.0	2.8	57.6	40	196.5	4.7	34.1	40
300	30000	128.8	3.1	58.4	40	216.5	5.2	35.3	40
330	33000	141.7	3.4	61.2	40	240.1	5.7	37.5	40
350	35000	150.3	3.6	76.4	40	254.7	6.1	50.1	40
400	40000	167.0	4.0	20.4	40	281.5	6.7	12.5	40
450	45000	187.9	4.5	21.6	40	322.1	7.7	10.9	40
500	50000	208.8	5.0	21.6	40	357.9	8.5	13.0	40

Mdel	Air flow	1 rows				2 rows			
		Rate heating capacity	Water flow rate	Water resistance	Water pipe diameter	Rate heating capacity	Water flow rate	Water resistance	Water pipe diameter
MKZS	m ³ /h	kW	L/s	kPa	DN	kW	L/s	kPa	DN
020	2000	9.0	0.2	1.4	32	16.6	0.4	7.5	32
030	3000	13.5	0.3	2.8	32	25.7	0.6	14.4	32
040	4000	18.6	0.4	4.2	32	33.2	0.8	21.9	32
050	5000	23.2	0.6	4.6	32	43.6	1.0	24.2	32
060	6000	28.7	0.7	7.6	32	50.6	1.2	38.3	32
070	7000	33.9	0.8	7.6	32	63.0	1.5	38.3	32
080	8000	39.9	1.0	10.7	32	73.1	1.7	54.5	32
100	10000	51.6	1.2	11.2	32	92.9	2.2	56.4	32
120	12000	59.0	1.4	19.2	32	106.2	2.5	11.4	32
150	15000	75.9	1.8	31.3	40	134.9	3.2	18.7	40
180	18000	92.3	2.2	42.9	40	161.9	3.9	25.6	40
210	21000	109.2	2.6	50.5	40	182.9	4.4	30.1	40
240	24000	124.8	3.0	74.8	40	212.4	5.1	44.0	40
270	27000	140.4	3.4	78.1	40	237.1	5.7	46.9	40
300	30000	156.0	3.7	79.2	40	261.3	6.2	47.2	40
330	33000	173.9	4.2	76.4	40	292.1	7.0	50.2	40
350	35000	184.4	4.4	79.9	40	309.8	7.4	67.0	40
400	40000	202.3	4.8	29.3	40	342.8	8.2	17.4	40
450	45000	227.6	5.4	31.2	40	385.7	9.2	15.4	40
500	50000	256.1	6.1	30.5	40	423.6	10.1	18.1	40

Notes: Heating (air return condition): Air inlet DB temperature is 15°C; hot water inlet temperature is 60°C; water outlet temperature is 50°C.
Heating (fresh air condition): Air inlet DB temperature is 7°C; hot water inlet temperature is 60°C; and water outlet temperature is 50°C.

Dimensions and weight

Vertical type standard unit I

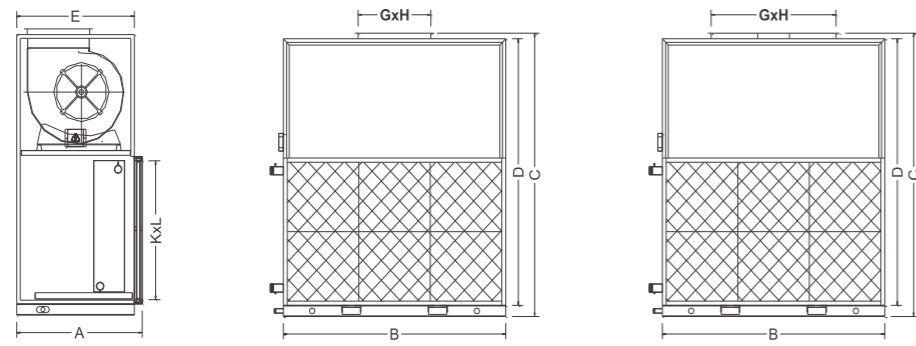

External nylon filter + Cooling coil + Fan

Model MKZS	A	B	C	D	E	G	H	K	L	Weight (kg)	
										Standard cooling capacity	High cooling capacity
020	640	900	1145	1000	580	232	262	840	390	137	143
030	640	1000	1245	1100	580	298	262	940	490	153	160
040	640	1100	1345	1200	580	331	289	1040	550	175	183
050	720	1100	1545	1400	660	309	341	1040	700	206	216
060	720	1200	1645	1500	660	395	341	1140	750	231	244
070	800	1200	1745	1600	740	373	404	1140	800	257	272
080	800	1400	1745	1600	740	373	404	1340	800	272	289
100	930	1600	1945	1800	870	430	478	1540	900	360	376
120	930	1700	1945	1800	870	557	478	1640	900	367	394
150	930	2000	2045	1900	870	1040	404	1940	1000	491	520
180	960	2200	2145	2000	900	1203	478	2140	1050	570	611
210	960	2500	2145	2000	900	1203	478	2440	1050	631	673
240	960	2800	2245	2100	900	1572	478	2740	1150	682	730

Notes: 1. When 50/100 mm evaporative humidifier used, the unit dimensions remain unchanged.
 2. Under standard configuration, front top air outlet (UF) is adopted.
 3. The above parameters listed are those of the MKZS**A series. For the MKZS**C serie units, 50 mm needs to be added to the A, B, C, D, and E values, respectively.

Vertical type standard unit II

Model MKZS	A	B	C	D	G	H	K	L	Weight (kg)	
									Standard cooling capacity	High cooling capacity
020	580	900	1380	1300	700	150	745	345	151	157
030	580	1000	1480	1400	700	150	845	445	168	176
040	580	1100	1680	1600	700	250	945	505	193	201
050	660	1100	1880	1800	700	250	945	655	227	238
060	660	1200	1980	1900	900	250	1045	705	254	268
070	740	1200	2180	2100	900	350	1045	755	283	299
080	740	1400	2180	2100	900	350	1245	755	299	318

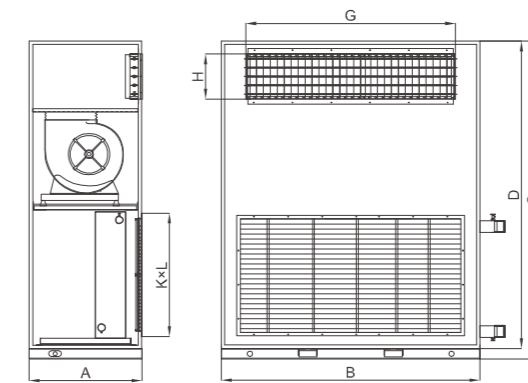

Return air louver + Cooling coil + Fan + Air outlet grille

Vertical type standard unit III

Model MKZS	A	B	C	D	Nozzle Qty	Nozzle specification	K	L	Weight (kg)	
									Standard cooling capacity	High cooling capacity
020	580	900	1630	1550	1	400	745	345	158	165
030	580	1000	1630	1550	2	315	845	445	177	185
040	580	1100	1830	1750	2	400	945	505	202	211
050	660	1100	2030	1950	2	400	945	655	238	249
060	660	1400	2280	2200	2	500	1245	705	267	282

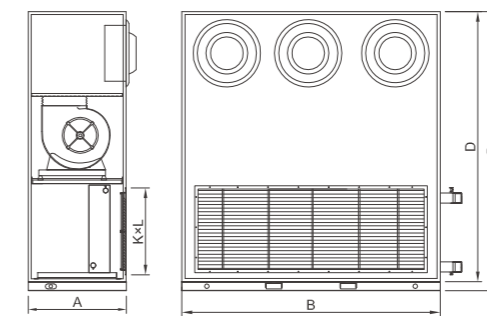

Return air louver + Cooling coil + Fan + Jet nozzle

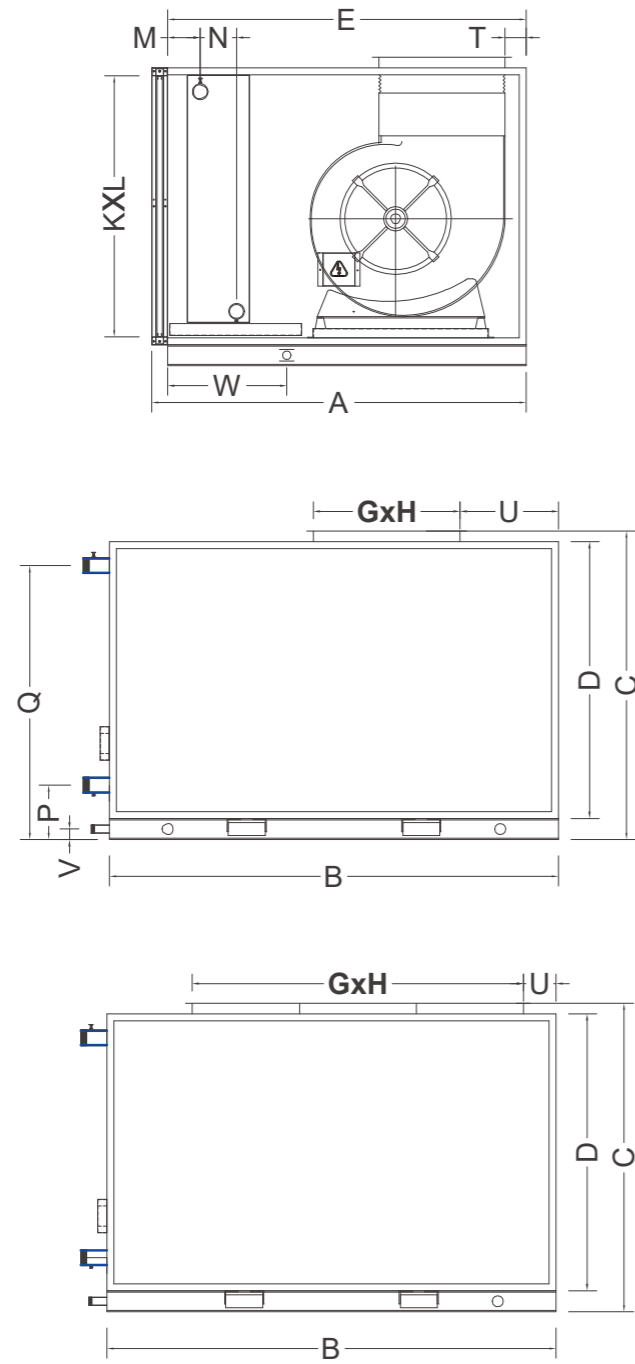

External nylon filter + Cooling coil + Fan

Model MKZS	A	B	C	D	E	G	H	K	L	Return air condition					
										M		N		P	
										S	H	S	H	S	H
020	1060	818	708	563	1000	232	262	758	503	94	94	73	73	196	196
030	1060	971	759	614	1000	298	262	911	554	94	94	73	73	200	200
040	1060	1073	810	665	1000	331	289	1013	605	94	94	73	73	200	200
050	1160	1124	912	767	1100	309	341	1064	707	94	94	73	73	200	200
060	1160	1277	912	767	1100	395	341	1217	707	94	94	73	73	200	200
070	1260	1277	1014	869	1200	373	404	1217	809	116	112	80	88	201	201
080	1260	1430	1014	869	1200	373	404	1370	809	116	112	80	88	201	201
100	1460	1430	1167	1022	1400	430	478	1370	962	116	112	80	89	201	201
120	1460	1685	1167	1022	1400	557	478	1625	962	116	112	80	89	201	201
150	1360	1991	1218	1073	1300	1040	404	1931	1013	116	112	80	88	201	201
180	1460	2195	1269	1124	1400	1203	478	2135	1064	116	112	80	88	201	221
210	1460	2348	1371	1226	1400	1203	478	2288	1166	111	112	90	88	221	221
240	1460	2654	1371	1226	1400	1572	478	2594	1166	111	112	90	88	208.3	221
270	1460	2705	1524	1379	1400	1572	478	2645	1319	111	112	90	88	208.3	221
300	1560	2705	1575	1430	1500	1572	478	2645	1370	111	112	90	88	208.3	221
330	1560	2909	1626	1481	1500	1588	569	2849	1421	106	106	100	100	208.3	221
350	1660	3062	1626	1481	1600	1776	638	3002	1421	106	106	100	100	208.3	221
400	1760	3062	1779	1634	1700	1776	638	3002	1574	114	121	83	124	238	238
450	1760	3062	2034	1889	1700	1776	638	3002	1829	114	121	83	124	238	238
500	1760	3113	2136	1991	1700	1776	638	3053	1931	114	121	83	124	238	238

Return air condition		Fresh air condition								T	U	V	W	Weight (kg)	
Q	H	M		N		P		Q						S	H
520	530	94	94	73	73	196	196	520	530	90	188	35	405	129	138
566	577	94	94	73	73	200	200	577	577	90	228	35	405	148	155
608	620	94	94	73	73	200	200	620	620	90	238	35	405	167	175
692	706	94	94	73	73	200	200	706	706	90	213	35	405	186	197
692	706	94	94	73	73	189.5	200	692	706	90	235	35	405	211	223
812	826	116	112	80	88	201	201	812	826	90	288	35	405	242	257
812	826	116	112	80	88	201	221	812	826	90	288	35	405	256	282
965	982	111	112	90	88	221	221	965	982	90	356	35	405	325	342
965	982	111	112	90	88	208.3	221	965	982	90	356	35	405	350	376
1015	1033	123	108	66	96	221	221	1015	1015	90	296	35	405	447	470
1066	1085	123	108	66	96	221	221	1066	1066	90	299	35	405	539	580
1168	1189	123	108	66	96	221	221	1168	1168	90	349	35	405	584	626
1168	1189	123	108	66	96	221	221	1168	1168	90	369	35	405	644	692
1269	1292	123	108	66	96	221	221	1269	1269	90	358	35	405	728	781
1371	1396	123	108	66	96	221	221	1371	1371	90	358	35	405	761	813
1422	1448	123	108	66	96	221	221	1422	1422	90	368	35	405	882	947
1422	1448	123	108	66	96	221	221	1422	1422	90	408	35	405	953	1022
1572	1572	114	121	83	124	238	238	1572	1572	90	408	35	455	986	1099
1762	1762	114	121	83	124	238	238	1762	1762	90	393	35	455	1070	1187
1000	1000	114	121	83	124	238	238	1000	1000	90	408	35	455	1097	1231

Notes:

1. S: Standard cooling capacity; H: High cooling capacity.
2. When 50/100 mm evaporative humidifier used, the unit dimensions remain unchanged; when 150/200 mm evaporative humidifier used, the A and E values of the unit need to be increased by 200 mm.
3. When plate type primary filter is adopted, the A value needs to be added by 40 mm.
4. When horizontal air outlet is adopted, the C value needs to be reduced by 40 mm.
5. The above parameters listed are those of the MKZS**A series. For the MKZS**C series units, 50 mm needs to be added to the A, B, C, D, and E values, respectively.
6. MKZS**C unit and other fans have different positioning dimensions, see product selection software for more details.

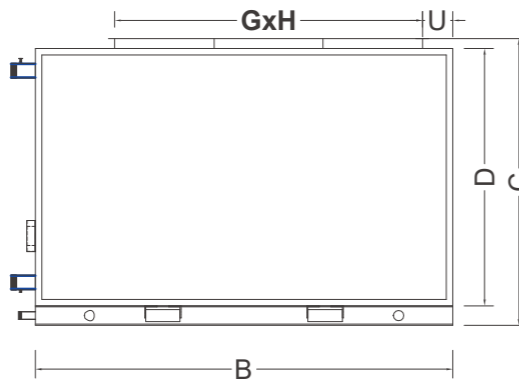
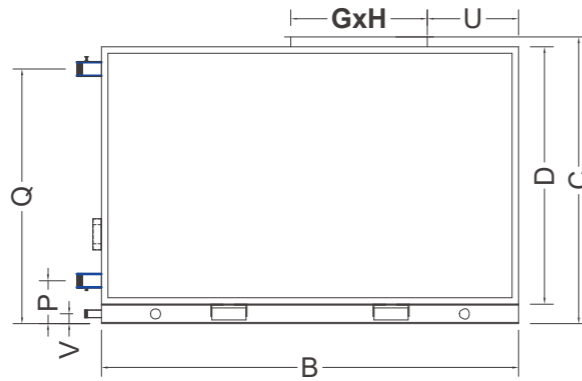
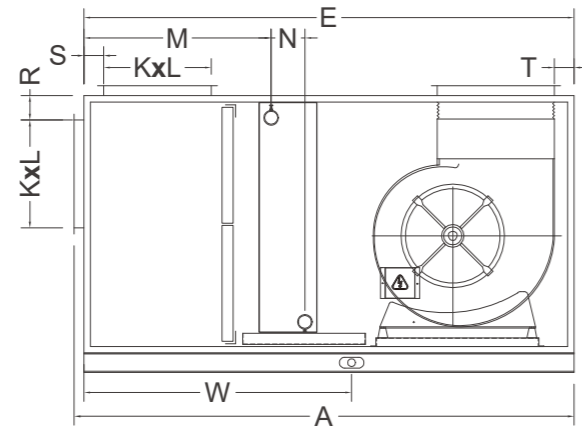

Mixing box + Primary efficiency filter + Cooling coil + Fan

Model MKZS	A	B	C	D	E	G	H	K	L	Return air condition						
										M		N		P		Q
										S	H	S	H	S	H	S
020	1565	818	708	563	1500	232	262	600	160	594	594	73	73	196	196	520
030	1565	971	759	614	1500	298	262	500	320	594	594	73	73	200	200	566
040	1565	1073	810	665	1500	331	289	630	320	594	594	73	73	200	200	608
050	1665	1124	912	767	1600	309	341	800	320	594	594	73	73	200	200	692
060	1665	1277	912	767	1600	395	341	800	320	594	594	73	73	200	200	692
070	1765	1277	1014	869	1700	373	404	1000	320	616	612	80	88	201	201	812
080	1765	1430	1014	869	1700	373	404	1000	320	616	612	80	88	201	201	812
100	2065	1430	1167	1022	2000	430	478	1000	400	716	712	80	89	201	201	965
120	2065	1685	1167	1022	2000	557	478	1250	400	716	712	80	89	201	201	965
150	1965	1991	1218	1073	1900	1040	404	1600	400	716	712	80	88	201	201	1015
180	2065	2195	1269	1124	2000	1203	478	1700	440	716	712	80	88	201	221	1066
210	2065	2348	1371	1226	2000	1203	478	1900	440	711	712	90	88	221	221	1168
240	2065	2654	1371	1226	2000	1572	478	2200	440	711	712	90	88	208.3	221	1168
330	2365	2909	1626	1481	2300	1588	569	2400	580	906	906	100	100	208.3	221	1422
350	2465	3062	1626	1481	2400	1776	638	2400	580	906	906	100	100	208.3	221	1422
400	2565	3062	1779	1634	2500	1776	638	2600	580	914	921	83	124	238	238	1572
450	2565	3062	2034	1889	2500	1776	638	2800	580	914	921	83	124	238	238	1762
500	2665	3113	2136	1991	2600	1776	638	2800	630	1014	1021	83	124	238	238	1000

Return air condition	Fresh air condition								R	S	T	U	V	W	Weight (kg)	
	M		N		P		Q								S	H
	S	H	S	H	S	H	S	H								
530	594	594	73	73	196	196	520	530	202	70	90	188	35	905	158	164
577	594	594	73	73	200	200	577	577	147	70	90	228	35	905	177	184
620	594	594	73	73	200	200	620	620	173	70	90	238	35	905	201	208
706	594	594	73	73	200	200	706	706	200	70	90	213	35	905	230	240
706	594	594	73	73	189.5	200	692	706	200	70	90	235	35	905	261	274
826	616	612	80	88	201	201	812	826	200	70	90	288	35	905	288	303
826	616	612	80	88	201	221	812	826	200	70	90	288	35	905	319	335
982	711	712	90	88	221	221	965	982	200	70	90	356	35	1005	392	408
982	711	712	90	88	208.3	221	965	982	200	70	90	356	35	1005	426	452
1033	723	708	66	96	221	221	1015	1015	200	70	90	296	35	1005	569	597
1085	723	708	66	96	221	221	1066	1066	200	70	90	299	35	1005	652	693
1189	723	708	66	96	221	221	1168	1168	200	70	90	349	35	1005	707	750
1189	723	708	66	96	221	221	1168	1168	200	70	90	369	35	1005	780	829
1448	923	908	66	96	221	221	1422	1422	200	70	90	368	35	1205	1084	1149
1448	923	908	66	96	221	221	1422	1422	200	70	90	408	35	1205	1170	1239
1572	914	921	83	124	238	238	1572	1572	200	70	90	408	35	1255	1202	1315
1762	914	921	83	124	238	238	1762	1762	200	70	90	393	35	1255	1285	1403
1000	1014	1021	83	124	238	238	1000	1000	200	70	90	408	35	1355	1324	1459

Notes:

1. When 50/100 mm evaporative humidifier used, the unit dimensions remain unchanged; when 150/200 mm evaporative humidifier used, the A and E values of the unit need to be increased by 200 mm.
2. The above parameters listed are those of the MKZS**A series. For the MKZS**C series units, 50 mm needs to be added to the A, B, C, D, and E values, respectively.
3. Mixing box + Primary efficiency filter + Cooling coil + Fan.

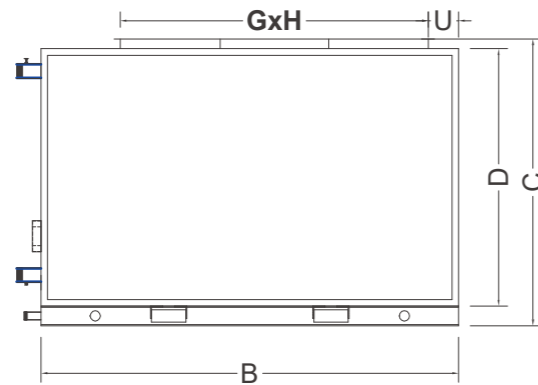
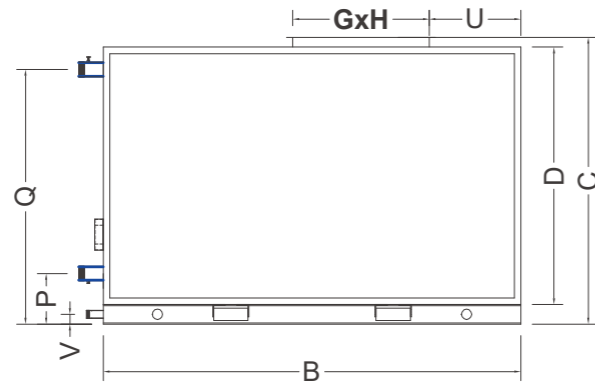
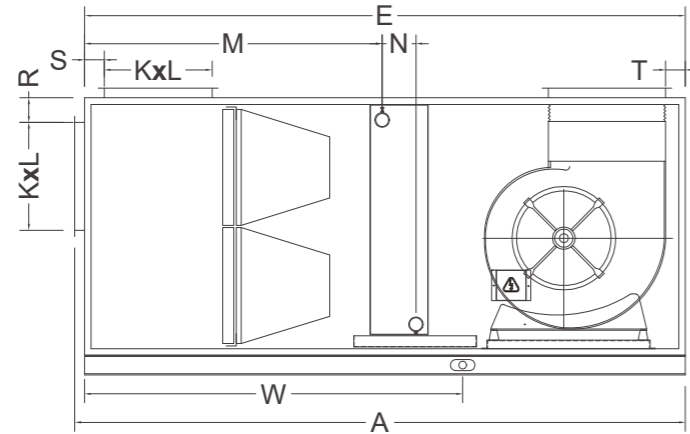

Mixing box + Primary efficiency filter + Medium efficiency filter + Cooling coil + Fan

Model MKZS	A	B	C	D	E	G	H	K	L	Return air condition						
										M		N		P		Q
										S	H	S	H	S	H	S
020	1965	818	708	563	1900	232	262	600	160	994	994	73	73	196	196	520
030	1965	971	759	614	1900	298	262	500	320	994	994	73	73	200	200	566
040	1965	1073	810	665	1900	331	289	630	320	994	994	73	73	200	200	608
050	2065	1124	912	767	2000	309	341	800	320	994	994	73	73	200	200	692
060	2065	1277	912	767	2000	395	341	800	320	994	994	73	73	200	200	692
070	2165	1277	1014	869	2100	373	404	1000	320	1016	1012	80	88	201	201	812
080	2165	1430	1014	869	2100	373	404	1000	320	1016	1012	80	88	201	201	812
100	2465	1430	1167	1022	2400	430	478	1000	400	1116	1112	80	89	201	201	965
120	2465	1685	1167	1022	2400	557	478	1250	400	1116	1112	80	89	201	201	965
150	2365	1991	1218	1073	2300	1040	404	1600	400	1116	1112	80	88	201	201	1015
210	2465	2348	1371	1226	2400	1203	478	1900	440	1111	1112	90	88	221	221	1168
240	2465	2654	1371	1226	2400	1572	478	2200	440	1111	1112	90	88	208.3	221	1168
270	2665	2705	1524	1379	2600	1572	478	2200	580	1311	1312	90	88	208.3	221	1269
300	2765	2705	1575	1430	2700	1572	478	2300	580	1311	1312	90	88	208.3	221	1371
330	2765	2909	1626	1481	2700	1588	569	2400	580	1306	1306	100	100	208.3	221	1422
350	2865	3062	1626	1481	2800	1776	638	2400	580	1306	1306	100	100	208.3	221	1422
400	2965	3062	1779	1634	2900	1776	638	2600	580	1314	1321	83	124	238	238	1572
450	2965	3062	2034	1889	2900	1776	638	2800	580	1314	1321	83	124	238	238	1762
500	3065	3113	2136	1991	3000	1776	638	2800	630	1414	1421	83	124	238	238	1000

Return air condition	Fresh air condition								R	S	T	U	V	W	Weight (kg)	
	M		N		P		Q								S	H
	S	H	S	H	S	H	S	H								
530	994	994	73	73	196	196	520	530	202	70	90	188	35	1305	176	181
577	994	994	73	73	200	200	577	577	147	70	90	228	35	1305	197	201
620	994	994	73	73	200	200	620	620	173	70	90	238	35	1305	224	232
706	994	994	73	73	200	200	706	706	200	70	90	213	35	1305	249	259
706	994	994	73	73	189.5	200	692	706	200	70	90	235	35	1305	282	295
826	1016	1012	80	88	201	201	812	826	200	70	90	288	35	1305	310	324
826	1016	1012	80	88	201	221	812	826	200	70	90	288	35	1305	345	362
982	1111	1112	90	88	221	221	965	982	200	70	90	356	35	1405	433	450
982	1111	1112	90	88	208.3	221	965	982	200	70	90	356	35	1405	471	494
1033	1123	1108	66	96	221	221	1015	1015	200	70	90	296	35	1405	622	645
1189	1123	1108	66	96	221	221	1168	1168	200	70	90	349	35	1405	809	842
1189	1123	1108	66	96	221	221	1168	1168	200	70	90	369	35	1405	885	922
1292	1323	1308	66	96	221	221	1269	1269	200	70	90	358	35	1605	978	1022
1396	1323	1308	66	96	221	221	1371	1371	200	70	90	358	35	1605	1033	1092
1448	1323	1308	66	96	221	221	1422	1422	200	70	90	368	35	1605	1185	1250
1448	1323	1308	66	96	221	221	1422	1422	200	70	90	408	35	1605	1246	1316
1572	1314	1321	83	124	238	238	1572	1572	200	70	90	408	35	1655	1306	1400
1762	1314	1321	83	124	238	238	1762	1762	200	70	90	393	35	1655	1421	1539
1000	1414	1421	83	124	238	238	1000	1000	200	70	90	408	35	1755	1462	1597

Notes:

- When 50/100 mm evaporative humidifier used, the unit dimensions remain unchanged; when 150/200 mm evaporative humidifier used, the A and E values of the unit need to be increased by 200 mm.
- The above parameters listed are those of the MKZS**A series. For the MKZS**C series units, 50 mm needs to be added to the A, B, C, D, and E values, respectively.
- For standard configuration, G3 plate type primary filter / M5 bag type medium efficiency filter is provided. G4 primary filter, M6/F7 medium efficiency filter, and high and medium efficiency bag type filter with antibacterial feature are optional.
- Mixing box + Primary efficiency filter + Medium efficiency filter + Cooling coil + Fan.

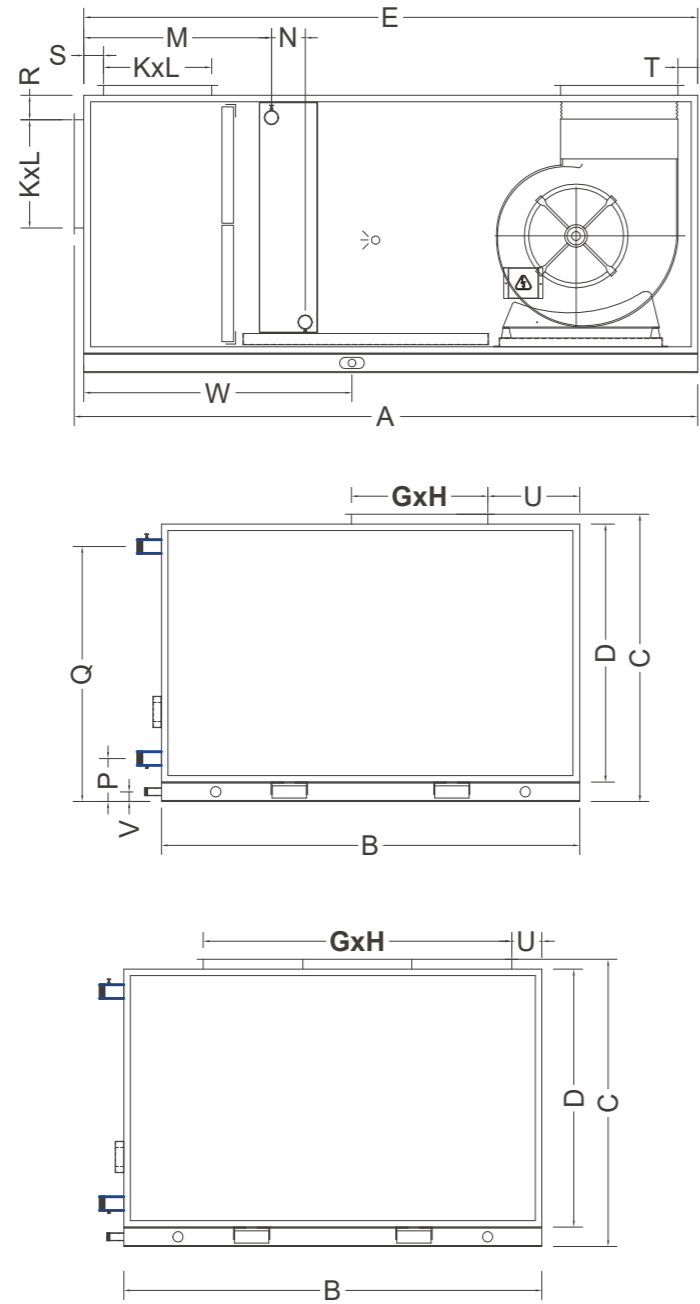

Mixing box + Primary efficiency filter + Cooling coil + Dry steam humidifier + Fan

Model MKZS	A	B	C	D	E	G	H	K	L	Return air condition						
										M		N		P		Q
										S	H	S	H	S	H	S
020	2065	818	708	563	2000	232	262	600	160	594	594	73	73	196	196	520
030	2065	971	759	614	2000	298	262	500	320	594	594	73	73	200	200	566
040	2065	1073	810	665	2000	331	289	630	320	594	594	73	73	200	200	608
050	2165	1124	912	767	2100	309	341	800	320	594	594	73	73	200	200	692
060	2165	1277	912	767	2100	395	341	800	320	594	594	73	73	200	200	692
070	2265	1277	1014	869	2200	373	404	1000	320	616	612	80	88	201	201	812
080	2265	1430	1014	869	2200	373	404	1000	320	616	612	80	88	201	201	812
100	2565	1430	1167	1022	2500	430	478	1000	400	716	712	80	89	201	201	965
120	2565	1685	1167	1022	2500	557	478	1250	400	716	712	80	89	201	201	965
150	2465	1991	1218	1073	2400	1040	404	1600	400	716	712	80	88	201	201	1015
210	2565	2348	1371	1226	2500	1203	478	1900	440	711	712	90	88	221	221	1168
240	2565	2654	1371	1226	2500	1572	478	2200	440	711	712	90	88	208.3	221	1168
270	2765	2705	1524	1379	2700	1572	478	2200	580	911	912	90	88	208.3	221	1269
300	2865	2705	1575	1430	2800	1572	478	2300	580	911	912	90	88	208.3	221	1371
330	2865	2909	1626	1481	2800	1588	569	2400	580	906	906	100	100	208.3	221	1422
350	2965	3062	1626	1481	2900	1776	638	2400	580	906	906	100	100	208.3	221	1422
400	3065	3062	1779	1634	3000	1776	638	2600	580	914	921	83	124	238	238	1572
450	3065	3062	2034	1889	3000	1776	638	2800	580	914	921	83	124	238	238	1762
500	3165	3113	2136	1991	3100	1776	638	2800	630	1014	1021	83	124	238	238	1000

Return air condition	Fresh air condition								R	S	T	U	V	W	Weight (kg)	
	M		N		P		Q								S	H
	S	H	S	H	S	H	S	H								
530	594	594	73	73	196	196	520	530	202	70	90	188	35	1405	163	169
577	594	594	73	73	200	200	577	577	147	70	90	228	35	1405	182	190
620	594	594	73	73	200	200	620	620	173	70	90	238	35	1405	207	214
706	594	594	73	73	200	200	706	706	200	70	90	213	35	1405	237	247
706	594	594	73	73	189.5	200	692	706	200	70	90	235	35	1405	269	282
826	616	612	80	88	201	201	812	826	200	70	90	288	35	1405	297	312
826	616	612	80	88	201	221	812	826	200	70	90	288	35	1405	329	345
982	711	712	90	88	221	221	965	982	200	70	90	356	35	1505	404	420
982	711	712	90	88	208.3	221	965	982	200	70	90	356	35	1505	439	466
1033	723	708	66	96	221	221	1015	1015	200	70	90	296	35	1505	586	615
1189	723	708	66	96	221	221	1168	1168	200	70	90	349	35	1505	728	773
1189	723	708	66	96	221	221	1168	1168	200	70	90	369	35	1505	803	854
1292	923	908	66	96	221	221	1269	1269	200	70	90	358	35	1705	939	994
1396	923	908	66	96	221	221	1371	1371	200	70	90	358	35	1705	987	1048
1448	923	908	66	96	221	221	1422	1422	200	70	90	368	35	1705	1117	1183
1448	923	908	66	96	221	221	1422	1422	200	70	90	408	35	1705	1205	1276
1572	914	921	83	124	238	238	1572	1572	200	70	90	408	35	1755	1238	1354
1762	914	921	83	124	238	238	1762	1762	200	70	90	393	35	1755	1324	1445
1000	1014	1021	83	124	238	238	1000	1000	200	70	90	408	35	1855	1364	1503

Note:
 1. The above parameters listed are those of the MKZS**A series. For the MKZS**C series units, 50 mm needs to be added to the A, B, C, D, and E values, respectively.
 2. MKZS**C unit and other fans have different positioning dimensions, see product selection software for more details.

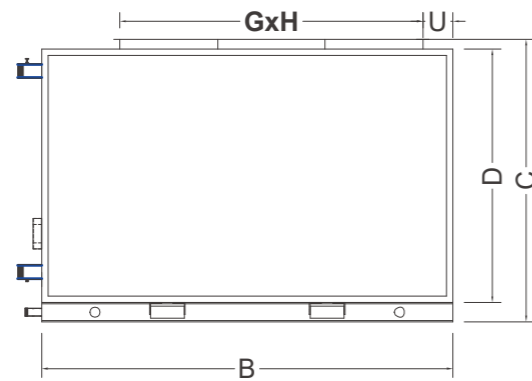
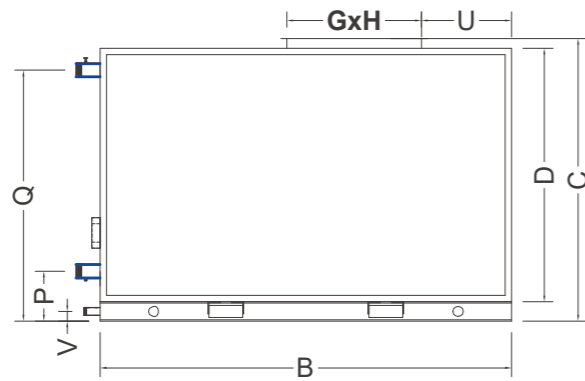
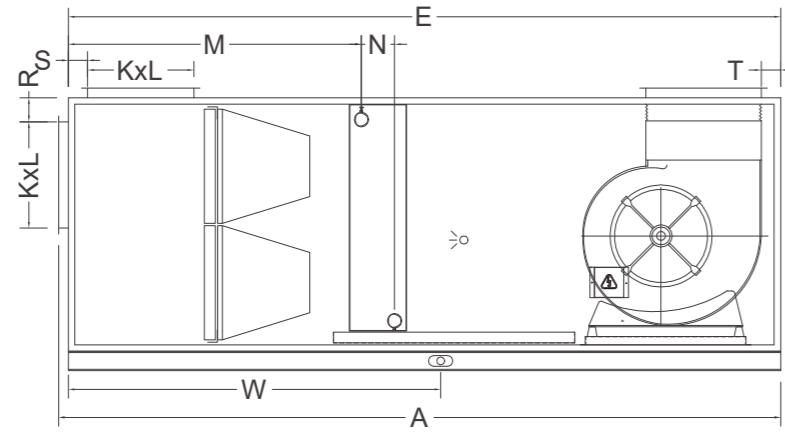

Mixing box + Primary efficiency filter + Medium efficiency filter + Cooling coil + Dry steam humidifier + Fan

Model MKZS	A	B	C	D	E	G	H	K	L	Return air condition						
										M		N		P		Q
										S	H	S	H	S	H	S
020	2465	818	708	563	2400	232	262	600	160	994	994	73	73	196	196	520
030	2465	971	759	614	2400	298	262	500	320	994	994	73	73	200	200	566
040	2465	1073	810	665	2400	331	289	630	320	994	994	73	73	200	200	608
050	2565	1124	912	767	2500	309	341	800	320	994	994	73	73	200	200	692
060	2565	1277	912	767	2500	395	341	800	320	994	994	73	73	200	200	692
070	2665	1277	1014	869	2600	373	404	1000	320	1016	1012	80	88	201	201	812
080	2665	1430	1014	869	2600	373	404	1000	320	1016	1012	80	88	201	201	812
100	2965	1430	1167	1022	2900	430	478	1000	400	1116	1112	80	89	201	201	965
120	2965	1685	1167	1022	2900	557	478	1250	400	1116	1112	80	89	201	201	965
150	2865	1991	1218	1073	2800	1040	404	1600	400	1116	1112	80	88	201	201	1015
210	2965	2348	1371	1226	2900	1203	478	1900	440	1111	1112	90	88	221	221	1168
240	2965	2654	1371	1226	2900	1572	478	2200	440	1111	1112	90	88	208.3	221	1168
270	3165	2705	1524	1379	3100	1572	478	2200	580	1311	1312	90	88	208.3	221	1269
300	3265	2705	1575	1430	3200	1572	478	2300	580	1311	1312	90	88	208.3	221	1371
330	3265	2909	1626	1481	3200	1588	569	2400	580	1306	1306	100	100	208.3	221	1422
350	3365	3062	1626	1481	3300	1776	638	2400	580	1306	1306	100	100	208.3	221	1422
400	3465	3062	1779	1634	3400	1776	638	2600	580	1314	1321	83	124	238	238	1572
450	3465	3062	2034	1889	3400	1776	638	2800	580	1314	1321	83	124	238	238	1762
500	3565	3113	2136	1991	3500	1776	638	2800	630	1414	1421	83	124	238	238	1000

Return air condition	Fresh air condition									R	S	T	U	V	W	Weight (kg)	
	M		N		P		Q		S							H	
	H	S	H	S	H	S	H	S									H
530	994	994	73	73	196	196	520	530	202	70	90	188	35	1805	181	186	
577	994	994	73	73	200	200	577	577	147	70	90	228	35	1805	203	207	
620	994	994	73	73	200	200	620	620	173	70	90	238	35	1805	231	239	
706	994	994	73	73	200	200	706	706	200	70	90	213	35	1805	256	267	
706	994	994	73	73	189.5	200	692	706	200	70	90	235	35	1805	290	304	
826	1016	1012	80	88	201	201	812	826	200	70	90	288	35	1805	319	334	
826	1016	1012	80	88	201	221	812	826	200	70	90	288	35	1805	355	373	
982	1111	1112	90	88	221	221	965	982	200	70	90	356	35	1905	446	464	
982	1111	1112	90	88	208.3	221	965	982	200	70	90	356	35	1905	485	509	
1033	1123	1108	66	96	221	221	1015	1015	200	70	90	296	35	1905	641	664	
1189	1123	1108	66	96	221	221	1168	1168	200	70	90	349	35	1905	833	867	
1189	1123	1108	66	96	221	221	1168	1168	200	70	90	369	35	1905	912	950	
1292	1323	1308	66	96	221	221	1269	1269	200	70	90	358	35	2105	1007	1053	
1396	1323	1308	66	96	221	221	1371	1371	200	70	90	358	35	2105	1064	1125	
1448	1323	1308	66	96	221	221	1422	1422	200	70	90	368	35	2105	1221	1288	
1448	1323	1308	66	96	221	221	1422	1422	200	70	90	408	35	2105	1283	1355	
1572	1314	1321	83	124	238	238	1572	1572	200	70	90	408	35	2155	1345	1442	
1762	1314	1321	83	124	238	238	1762	1762	200	70	90	393	35	2155	1464	1585	
1000	1414	1421	83	124	238	238	1000	1000	200	70	90	408	35	2255	1506	1645	

Notes:

- The above parameters listed are those of the MKZS**A series. For the MKZS**C series units, 50 mm needs to be added to the A, B, C, D, and E values, respectively.
- The standard plate type primary filter is G3, the bag type medium efficiency filter is M5, the primary efficiency can be customized with G4, the medium efficiency can be customized with M6, F7 or antibacterial high efficiency bag filter;
- MKZS**C unit and other fans have different positioning dimensions, see product selection software for more details;

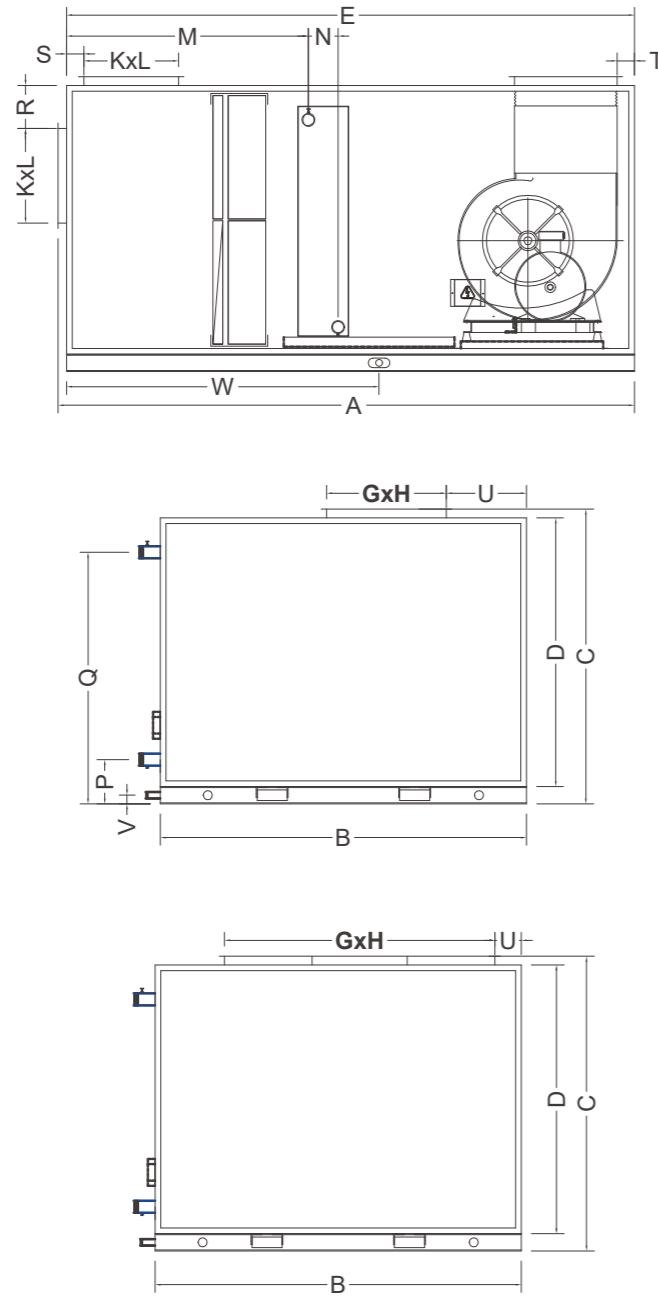

Mixing box + All-in-one plate type electrostatic filter + Cooling coil + Fan

Model MKZS	A	B	C	D	E	G	H	K	L	Return air condition						
										M		N		P		Q
										S	H	S	H	S	H	S
020	1965	818	708	563	1900	232	262	600	160	994	994	73	73	196	196	520
030	1965	971	759	614	1900	298	262	500	320	994	994	73	73	200	200	566
040	1965	1073	810	665	1900	331	289	630	320	994	994	73	73	200	200	608
050	2065	1124	912	767	2000	309	341	800	320	994	994	73	73	200	200	692
060	2065	1277	912	767	2000	395	341	800	320	994	994	73	73	200	200	692
070	2165	1277	1014	869	2100	373	404	1000	320	1016	1012	80	88	201	201	812
080	2165	1430	1014	869	2100	373	404	1000	320	1016	1012	80	88	201	201	812
100	2465	1430	1167	1022	2400	430	478	1000	400	1116	1112	80	89	201	201	965
120	2465	1685	1167	1022	2400	557	478	1250	400	1116	1112	80	89	201	201	965
150	2365	1991	1218	1073	2300	1040	404	1600	400	1116	1112	80	88	201	201	1015
210	2465	2348	1371	1226	2400	1203	478	1900	440	1111	1112	90	88	221	221	1168
240	2465	2654	1371	1226	2400	1572	478	2200	440	1111	1112	90	88	208.3	221	1168
270	2665	2705	1524	1379	2600	1572	478	2200	580	1311	1312	90	88	208.3	221	1269
300	2765	2705	1575	1430	2700	1572	478	2300	580	1311	1312	90	88	208.3	221	1371
330	2765	2909	1626	1481	2700	1588	569	2400	580	1306	1306	100	100	208.3	221	1422
350	2865	3062	1626	1481	2800	1776	638	2400	580	1306	1306	100	100	208.3	221	1422
400	2965	3062	1779	1634	2900	1776	638	2600	580	1314	1321	83	124	238	238	1572
450	2965	3062	2034	1889	2900	1776	638	2800	580	1314	1321	83	124	238	238	1762
500	3065	3113	2136	1991	3000	1776	638	2800	630	1414	1421	83	124	238	238	1000

Return air condition	Fresh air condition								R	S	T	U	V	W	Weight (kg)	
	M		N		P		Q								S	H
	S	H	S	H	S	H	S	H								
530	994	994	73	73	196	196	520	530	202	70	90	188	35	1305	188	193
577	994	994	73	73	200	200	577	577	147	70	90	228	35	1305	215	219
620	994	994	73	73	200	200	620	620	173	70	90	238	35	1305	254	262
706	994	994	73	73	200	200	706	706	200	70	90	213	35	1305	279	289
706	994	994	73	73	189.5	200	692	706	200	70	90	235	35	1305	312	325
826	1016	1012	80	88	201	201	812	826	200	70	90	288	35	1305	352	366
826	1016	1012	80	88	201	221	812	826	200	70	90	288	35	1305	387	404
982	1111	1112	90	88	221	221	965	982	200	70	90	356	35	1405	493	510
982	1111	1112	90	88	208.3	221	965	982	200	70	90	356	35	1405	531	554
1033	1123	1108	66	96	221	221	1015	1015	200	70	90	296	35	1405	712	735
1189	1123	1108	66	96	221	221	1168	1168	200	70	90	349	35	1405	917	950
1189	1123	1108	66	96	221	221	1168	1168	200	70	90	369	35	1405	1005	1042
1292	1323	1308	66	96	221	221	1269	1269	200	70	90	358	35	1605	1110	1154
1396	1323	1308	66	96	221	221	1371	1371	200	70	90	358	35	1605	1177	1236
1448	1323	1308	66	96	221	221	1422	1422	200	70	90	368	35	1605	1329	1394
1448	1323	1308	66	96	221	221	1422	1422	200	70	90	408	35	1605	1414	1484
1572	1314	1321	83	124	238	238	1572	1572	200	70	90	408	35	1655	1498	1592
1762	1314	1321	83	124	238	238	1762	1762	200	70	90	393	35	1655	1567	1755
1000	1414	1421	83	124	238	238	1000	1000	200	70	90	408	35	1755	1714	1849

Notes:

- The above parameters listed are those of the MKZS**A series. For the MKZS**C series units, 50 mm needs to be added to the A, B, C, D, and E values, respectively.
- MKZS**C unit and other fans have different positioning dimensions, see product selection software for more details

Horizontal type standard unit IX

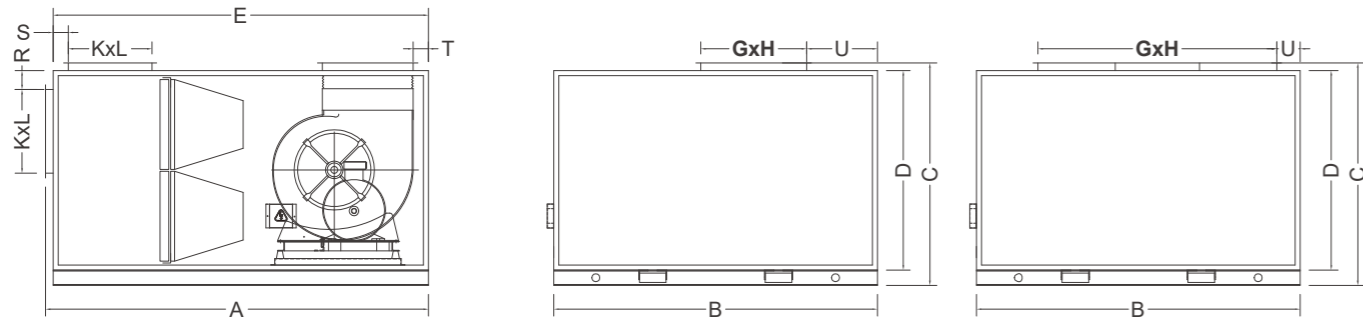

Mixing box + Primary efficiency filter + Medium efficiency filter + Fan

Model MKZS	A	B	C	D	E	G	H	K	L	R	S	T	U	Weight (kg)
020	1565	818	708	563	1500	232	262	600	160	202	70	90	188	146
030	1565	971	759	614	1500	298	262	500	320	147	70	90	228	163
040	1565	1073	810	665	1500	331	289	630	320	173	70	90	238	187
050	1665	1124	912	767	1600	309	341	800	320	200	70	90	213	210
060	1665	1277	912	767	1600	395	341	800	320	200	70	90	235	235
070	1765	1277	1014	869	1700	373	404	1000	320	200	70	90	288	258
080	1765	1430	1014	869	1700	373	404	1000	320	200	70	90	288	287
100	2065	1430	1167	1022	2000	430	478	1000	400	200	70	90	356	360
120	2065	1685	1167	1022	2000	557	478	1250	400	200	70	90	356	374
150	1965	1991	1218	1073	1900	1040	404	1600	400	200	70	90	296	513
180	2065	2195	1269	1124	2000	1203	478	1700	440	200	70	90	299	570
210	2065	2348	1371	1226	2000	1203	478	1900	440	200	70	90	349	621
240	2065	2654	1371	1226	2000	1572	478	2200	440	200	70	90	369	682

- Notes:
- The above parameters listed are those of the MKZS**A series. For the MKZS**C series units, 50 mm needs to be added to the A, B, C, D, and E values, respectively.
 - For standard configuration, G3 plate type primary filter / M5 bag type medium efficiency filter is provided. G4 primary filter, M6/F7 medium efficiency filter, and high and medium efficiency bag type filter with antibacterial feature are optional.
 - MKZS**C unit and other fans have different positioning dimensions, see product selection software for more details.

Horizontal type standard unit X

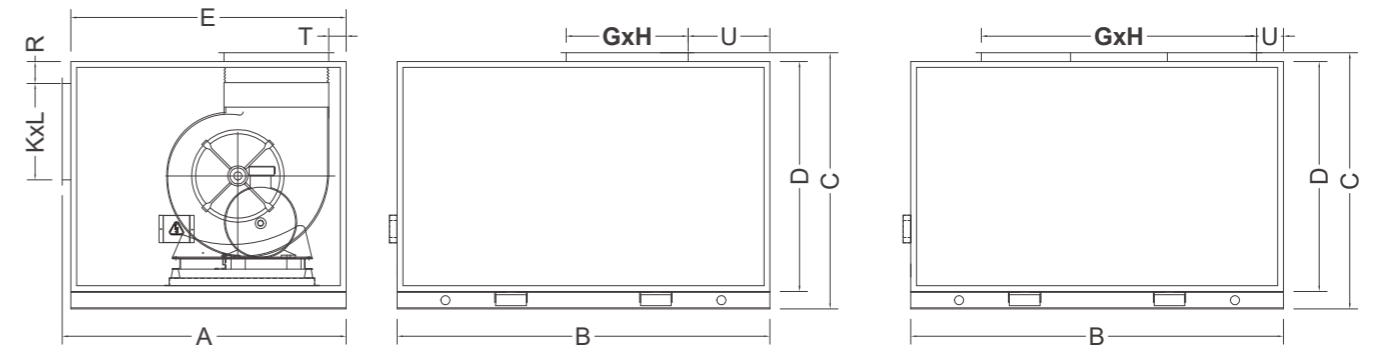

Air inlet + Fan

Model MKZS	A	B	C	D	E	G	H	K	L	R	T	U	Weight (kg)
020	665	818	708	563	600	232	262	600	160	202	90	188	125
030	665	971	759	614	600	298	262	500	320	147	90	228	148
040	665	1073	810	665	600	331	289	630	320	173	90	238	167
050	765	1124	912	767	700	309	341	800	320	200	90	213	186
060	765	1277	912	767	700	395	341	800	320	200	90	235	211
070	865	1277	1014	869	800	373	404	1000	320	200	90	288	242
080	865	1430	1014	869	800	373	404	1000	320	200	90	288	256
100	965	1430	1167	1022	900	430	478	1000	400	200	90	356	325
120	965	1685	1167	1022	900	557	478	1250	400	200	90	356	350
150	865	1991	1014	869	800	1040	404	1600	400	200	90	296	447
180	965	2195	1167	1022	900	1203	478	1700	440	200	90	299	539
210	965	2348	1167	1022	900	1203	478	1900	440	200	90	349	584
240	965	2654	1167	1022	900	1572	478	2200	440	200	90	369	644
270	965	2705	1167	1022	900	1572	478	2200	580	200	90	358	728
300	965	2705	1167	1022	900	1572	478	2300	580	200	90	358	761

- Notes:
- The above parameters listed are those of the MKZS**A series. For the MKZS**C series units, 50 mm needs to be added to the A, B, C, D, and E values, respectively.
 - MKZS**C unit and other fans have different positioning dimensions, see product selection software for more details.

Fan Motor Power

Vertical type standard unit

Midel MKZS	Air flow (m³/h)	Rows of surface	Motor power (kW) corresponding to external pressure (Pa)												
			170	220	270	320	370	420	470	520	570	620	670	720	770
020	2000	S	0.55	0.55	0.55	0.55	0.55								
		H	0.55	0.55	0.55	0.55	0.75								
030	3000	S	0.55	0.75	0.75	0.75	1.1								
		H	0.75	0.75	0.75	1.1	1.1								
040	4000	S		1.1	1.1	1.1	1.1	1.1	1.5						
		H		1.1	1.1	1.1	1.1	1.5	1.5						
050	5000	S		1.1	1.1	1.1	1.5	1.5	1.5						
		H		1.1	1.1	1.5	1.5	1.5	1.5						
060	6000	S		1.5	1.5	1.5	2.2	2.2	2.2						
		H		1.5	1.5	2.2	2.2	2.2	2.2						
070	7000	S		1.5	1.5	1.5	2.2	2.2	2.2	2.2					
		H		1.5	1.5	2.2	2.2	2.2	2.2	2.2					
800	8000	S			2.2	2.2	2.2	2.2	2.2	3.0	3.0				
		H			2.2	2.2	2.2	2.2	3.0	3.0	3.0				
100	10000	S		2.2	3.0	3.0	3.0	3.0	3.0	4.0					
		H		3.0	3.0	3.0	3.0	3.0	4.0	4.0					
120	12000	S		2.2	3.0	3.0	3.0	3.0	4.0	4.0	4.0	4.0			
		H		3.0	3.0	3.0	3.0	4.0	4.0	4.0	4.0	5.5			
150	15000	S		3.0	4.0	4.0	4.0	5.5	5.5	5.5	5.5	5.5			
		H		4.0	4.0	4.0	5.5	5.5	5.5	5.5	5.5	7.5			
180	18000	S				5.5	5.5	5.5	5.5	7.5	7.5	7.5			
		H				5.5	5.5	5.5	7.5	7.5	7.5	7.5			
210	21000	S				5.5	7.5	7.5	7.5	7.5	11.0	11.0			
		H				7.5	7.5	7.5	7.5	11.0	11.0	11.0			
240	24000	S				5.5	7.5	7.5	7.5	11.0	11.0	11.0	11.0		
		H				7.5	7.5	7.5	11.0	11.0	11.0	11.0	11.0		

Notes:

1. The above parameters are power values of "Vertical type standard unit I" corresponding to the external static pressure.
2. The motor power of each model of "Vertical Standard Unit II" and "Vertical Standard Unit III" is shown in the product selection software.

Horizontal type standard unit I

Midel MKZS	Air flow (m³/h)	Rows of surface	Motor power (kW) corresponding to external pressure (Pa)												
			220	270	320	370	420	470	520	570	620	670	720		
020	2000	S	0.55	0.55	0.55	0.55	0.75								
		H	0.55	0.55	0.55	0.75	0.75								
030	3000	S	0.75	0.75	0.75	1.1	1.1								
		H	0.75	0.75	1.1	1.1	1.1								
040	4000	S		1.1	1.1	1.1	1.1	1.5							
		H		1.1	1.1	1.1	1.5	1.5							
050	5000	S			1.1	1.5	1.5	1.5	1.5	1.5	1.5	1.5	2.2		
		H			1.5	1.5	1.5	1.5	1.5	2.2	2.2				
060	6000	S			1.5	2.2	2.2	2.2	2.2	2.2	2.2	2.2	2.2		
		H			2.2	2.2	2.2	2.2	2.2	2.2	3.0				
070	7000	S			1.5	2.2	2.2	2.2	2.2	2.2	2.2	2.2	2.2		
		H			2.2	2.2	2.2	2.2	2.2	2.2	3.0				
800	8000	S				2.2	2.2	2.2	3.0	3.0	3.0	3.0	3.0	3.0	
		H				2.2	2.2	2.2	3.0	3.0	3.0	3.0	3.0	3.0	
100	10000	S				3.0	3.0	3.0	3.0	4.0	4.0	4.0	4.0		
		H				3.0	3.0	3.0	4.0	4.0	4.0	4.0	4.0		
120	12000	S				3.0	3.0	3.0	4.0	4.0	4.0	4.0	4.0		
		H				3.0	3.0	4.0	4.0	4.0	4.0	4.0	4.0		
150	15000	S				4.0	4.0	5.5	5.5	5.5	5.5	5.5	5.5		
		H				4.0	4.0	5.5	5.5	5.5	5.5	7.5			
180	18000	S				5.5	5.5	5.5	5.5	7.5	7.5	7.5	7.5		
		H				5.5	5.5	5.5	7.5	7.5	7.5	7.5	7.5		
210	21000	S				5.5	7.5	7.5	7.5	7.5	11.0	11.0			
		H				7.5	7.5	7.5	7.5	11.0	11.0	11.0			
240	24000	S				5.5	7.5	7.5	7.5	11.0	11.0	11.0	11.0		
		H				7.5	7.5	7.5	11.0	11.0	11.0	11.0	11.0		
270	27000	S				7.5	7.5	11.0	11.0	11.0	11.0	11.0	11.0	11.0	11.0
		H				7.5	11.0	11.0	11.0	11.0	11.0	11.0	11.0	11.0	15.0
300	30000	S					11.0	11.0	11.0	11.0	11.0	11.0	11.0	15.0	15.0
		H					11.0	11.0	11.0	11.0	11.0	11.0	15.0	15.0	15.0
330	33000	S						11.0	11.0	15.0	15.0	15.0	15.0		
		H						11.0	15.0	15.0	15.0	15.0	15.0		
350	35000	S						11.0	11.0	11.0	15.0	15.0			
		H						11.0	11.0	15.0	15.0	15.0			
400	40000	S						15.0	15.0	15.0	15.0	15.0			
		H						15.0	15.0	15.0	15.0	18.5			
450	45000	S							15.0	15.0	18.5	18.5	18.5		
		H							15.0	18.5	18.5	18.5	18.5		
500	50000	S								18.5	18.5	22.0	22.0	22.0	
		H								18.5	22.0	22.0	22.0		

Horizontal type standard unit II

Mldel MKZS	Air flow (m³/h)	Rows of surface	Motor power (kW) corresponding to external pressure (Pa)										
			220	270	320	370	420	470	520	570	620	670	720
020	2000	S	0.55	0.55	0.75	0.75	0.75						
		H	0.55	0.75	0.75	0.75	0.75						
030	3000	S	0.75	0.75	1.1	1.1	1.1						
		H	0.75	1.1	1.1	1.1	1.1						
040	4000	S		1.1	1.1	1.1	1.5	1.5					
		H		1.1	1.1	1.5	1.5	1.5					
050	5000	S		1.1	1.5	1.5	1.5	1.5					
		H		1.5	1.5	1.5	1.5	2.2					
060	6000	S		1.5	2.2	2.2	2.2	2.2	2.2				
		H		2.2	2.2	2.2	2.2	2.2	3.0				
070	7000	S		1.5	2.2	2.2	2.2	2.2	2.2				
		H		2.2	2.2	2.2	2.2	2.2	3.0				
800	8000	S				2.2	2.2	3.0	3.0	3.0	3.0		
		H				2.2	3.0	3.0	3.0	3.0	3.0		
100	10000	S			3.0	3.0	4.0	4.0	4.0	4.0			
		H			3.0	4.0	4.0	4.0	4.0	4.0			
120	12000	S			3.0	3.0	4.0	4.0	4.0	5.5			
		H			3.0	4.0	4.0	4.0	5.5	5.5			
150	15000	S				5.5	5.5	5.5	5.5	5.5	7.5		
		H				5.5	5.5	5.5	5.5	7.5	7.5		
180	18000	S				5.5	5.5	7.5	7.5	7.5	7.5		
		H				5.5	7.5	7.5	7.5	7.5	7.5		
210	21000	S				7.5	7.5	7.5	11.0	11.0	11.0		
		H				7.5	7.5	11.0	11.0	11.0	11.0		
240	24000	S				7.5	11.0	11.0	11.0	11.0			
		H				11.0	11.0	11.0	11.0	11.0			
330	33000	S					11.0	15.0	15.0	15.0	15.0	15.0	
		H					15.0	15.0	15.0	15.0	15.0	15.0	
350	35000	S					11.0	15.0	15.0	15.0	15.0	15.0	
		H					15.0	15.0	15.0	15.0	15.0	15.0	
400	40000	S						15.0	15.0	15.0	18.5	18.5	
		H						15.0	15.0	18.5	18.5	18.5	
450	45000	S							18.5	18.5	18.5	18.5	22.0
		H							18.5	18.5	18.5	22.0	22.0
500	50000	S								22.0	22.0	22.0	
		H								22.0	22.0		

Horizontal type standard unit III

Mldel MKZS	Air flow (m³/h)	Rows of surface	Motor power (kW) corresponding to external pressure (Pa)										
			220	270	320	370	420	470	520	570	620	670	720
020	2000	S	0.55	0.55	0.75	0.75	0.75						
		H	0.55	0.75	0.75	0.75	0.75						
030	3000	S	0.75	0.75	1.1	1.1	1.1						
		H	0.75	1.1	1.1	1.1	1.1						
040	4000	S		1.1	1.1	1.1	1.5	1.5					
		H		1.1	1.1	1.5	1.5	1.5					
050	5000	S		1.1	1.5	1.5	1.5	1.5					
		H		1.5	1.5	1.5	1.5	2.2					
060	6000	S		1.5	2.2	2.2	2.2	2.2	2.2				
		H		2.2	2.2	2.2	2.2	2.2	3.0				
070	7000	S		1.5	2.2	2.2	2.2	2.2	2.2				
		H		2.2	2.2	2.2	2.2	2.2	3.0				
800	8000	S				2.2	2.2	3.0	3.0	3.0	3.0		
		H				2.2	3.0	3.0	3.0	3.0	3.0		
100	10000	S			3.0	3.0	4.0	4.0	4.0	4.0			
		H			3.0	4.0	4.0	4.0	4.0	4.0			
120	12000	S			3.0	3.0	4.0	4.0	4.0	5.5			
		H			3.0	4.0	4.0	4.0	5.5	5.5			
150	15000	S				5.5	5.5	5.5	5.5	5.5	7.5		
		H				5.5	5.5	5.5	5.5	7.5	7.5		
210	21000	S				5.5	5.5	7.5	7.5	7.5	7.5		
		H				5.5	7.5	7.5	7.5	7.5	7.5		
240	24000	S				7.5	7.5	7.5	11.0	11.0	11.0		
		H				7.5	7.5	11.0	11.0	11.0	11.0		
270	27000	S				7.5	11.0	11.0	11.0	11.0			
		H				11.0	11.0	11.0	11.0	11.0			
300	30000	S									11.0	11.0	15.0
		H									11.0	15.0	15.0
330	33000	S									11.0	15.0	15.0
		H									15.0	15.0	15.0
350	35000	S									11.0	15.0	15.0
		H									15.0	15.0	15.0
400	40000	S										15.0	15.0
		H										15.0	15.0
450	45000	S										15.0	15.0
		H										15.0	15.0
450	45000	S										18.5	18.5
		H										18.5	18.5
500	50000	S										18.5	18.5
		H										18.5	18.5
500	50000	S										22.0	22.0
		H										22.0	22.0

Horizontal type standard unit IV

Mldel MKZS	Air flow (m³/h)	Rows of surface	Motor power (kW) corresponding to external pressure (Pa)										
			170	220	270	320	370	420	470	520	570	620	670
020	2000	S	0.55	0.75	0.75	0.75	0.75	1.1	1.1	1.1			
		H	0.75	0.75	0.75	0.75	1.1	1.1	1.1	1.1			
030	3000	S	0.75	1.1	1.1	1.1	1.1	1.1	1.5				
		H	1.1	1.1	1.1	1.1	1.1	1.5					
040	4000	S		1.1	1.1	1.5	1.5	1.5	2.2	2.2	2.2		
		H		1.1	1.5	1.5	1.5	2.2	2.2	2.2	2.2		
050	5000	S		1.5	1.5	1.5	1.5	2.2	2.2	2.2	2.2		
		H		1.5	1.5	1.5	2.2	2.2	2.2	2.2	2.2		
060	6000	S		2.2	2.2	2.2	2.2	2.2	3.0	3.0	3.0		
		H		2.2	2.2	2.2	2.2	3.0	3.0	3.0			
070	7000	S			2.2	2.2	2.2	2.2	3.0	3.0	3.0		
		H			2.2	2.2	2.2	3.0	3.0	3.0	3.0		
800	8000	S				2.2	3.0	3.0	3.0	3.0	3.0	4.0	
		H				3.0	3.0	3.0	3.0	3.0	4.0	4.0	
100	10000	S					4.0	4.0	4.0	4.0	5.5		
		H					4.0	4.0	4.0	5.5	5.5		
120	12000	S					4.0	4.0	5.5	5.5	5.5		
		H					4.0	5.5	5.5	5.5	5.5		
150	15000	S					5.5	5.5	5.5	7.5	7.5		
		H					5.5	5.5	7.5	7.5	7.5		
210	21000	S					7.5	11.0	11.0	11.0	11.0		
		H					11.0	11.0	11.0	11.0	11.0		
240	24000	S					11.0	11.0	11.0	11.0	11.0		
		H					11.0	11.0	11.0	11.0			
270	27000	S					11.0	11.0	11.0	11.0	15.0		
		H					11.0	11.0	11.0	15.0	15.0		
300	30000	S						11.0	15.0	15.0	15.0	15.0	
		H						15.0	15.0	15.0	15.0		
330	33000	S					15.0	15.0	15.0	15.0	15.0	15.0	
		H					15.0	15.0	15.0	15.0	15.0	18.5	
350	35000	S					15.0	15.0	15.0	15.0	15.0	15.0	
		H					15.0	15.0	15.0	15.0	15.0	18.5	
400	40000	S					15.0	15.0	15.0	18.5	18.5	18.5	
		H					15.0	15.0	18.5	18.5	18.5	18.5	
450	45000	S						18.5	18.5	18.5	18.5	22.0	22.0
		H						18.5	18.5	18.5	22.0	22.0	
500	50000	S						22.0	22.0	22.0			
		H						22.0	22.0				
600	60000	S					18.5	18.5	22.0	22.0	30.0	30.0	
		H					18.5	22.0	22.0	30.0	30.0		

Horizontal type standard unit V

Mldel MKZS	Air flow (m³/h)	Rows of surface	Motor power (kW) corresponding to external pressure (Pa)										
			170	220	270	320	370	420	470	520	570	620	670
020	2000	S	0.55	0.75	0.75	0.75	0.75	1.1	1.1	1.1			
		H	0.75	0.75	0.75	0.75	1.1	1.1	1.1	1.1			
030	3000	S	0.75	1.1	1.1	1.1	1.1	1.1	1.5				
		H	1.1	1.1	1.1	1.1	1.1	1.5					
040	4000	S		1.1	1.1	1.5	1.5	1.5	2.2	2.2	2.2		
		H		1.1	1.5	1.5	1.5	2.2	2.2	2.2	2.2		
050	5000	S		1.5	1.5	1.5	1.5	2.2	2.2	2.2	2.2		
		H		1.5	1.5	1.5	2.2	2.2	2.2	2.2	2.2		
060	6000	S		2.2	2.2	2.2	2.2	2.2	3.0	3.0	3.0		
		H		2.2	2.2	2.2	2.2	3.0	3.0	3.0			
070	7000	S			2.2	2.2	2.2	2.2	3.0	3.0	3.0		
		H			2.2	2.2	2.2	3.0	3.0	3.0	3.0		
800	8000	S				2.2	3.0	3.0	3.0	3.0	3.0	4.0	
		H				3.0	3.0	3.0	3.0	3.0	4.0	4.0	
100	10000	S					4.0	4.0	4.0	4.0	5.5		
		H					4.0	4.0	4.0	5.5	5.5		
120	12000	S					4.0	4.0	5.5	5.5	5.5		
		H					4.0	5.5	5.5	5.5	5.5		
150	15000	S					5.5	5.5	5.5	7.5	7.5		
		H					5.5	5.5	7.5	7.5	7.5		
210	21000	S					7.5	11.0	11.0	11.0	11.0		
		H					11.0	11.0	11.0	11.0	11.0		
240	24000	S					11.0	11.0	11.0	11.0	11.0		
		H					11.0	11.0	11.0	11.0			
270	27000	S					11.0	11.0	11.0	11.0	15.0		
		H					11.0	11.0	11.0	15.0	15.0		
300	30000	S						11.0	15.0	15.0	15.0	15.0	
		H						15.0	15.0	15.0	15.0		
330	33000	S					15.0	15.0	15.0	15.0	15.0	15.0	
		H					15.0	15.0	15.0	15.0	15.0	18.5	
350	35000	S					15.0	15.0	15.0	15.0	15.0	15.0	
		H					15.0	15.0	15.0	15.0	15.0	18.5	
400	40000	S					15.0	15.0	15.0	18.5	18.5	18.5	
		H					15.0	15.0	18.5	18.5	18.5	18.5	
450	45000	S						18.5	18.5	18.5	18.5	22.0	22.0
		H						18.5	18.5	18.5	22.0	22.0	
500	50000	S						22.0	22.0	22.0			
		H						22.0	22.0				
600	60000	S					18.5	18.5	22.0	22.0	30.0	30.0	
		H					18.5	22.0	22.0	30.0	30.0		

Horizontal type standard unit VI

Mldel MKZS	Air flow (m³/h)	Rows of surface	Motor power (kW) corresponding to external pressure (Pa)										
			190	240	290	340	390	440	490	540	590	640	690
020	2000	S	0.55	0.55	0.75	0.75	0.75						
		H	0.55	0.75	0.75	0.75	0.75						
030	3000	S	0.75	0.75	1.1	1.1	1.1						
		H	0.75	1.1	1.1	1.1	1.1						
040	4000	S		1.1	1.1	1.1	1.5	1.5					
		H		1.1	1.1	1.5	1.5	1.5					
050	5000	S		1.1	1.5	1.5	1.5	1.5					
		H		1.5	1.5	1.5	1.5	2.2					
060	6000	S		1.5	2.2	2.2	2.2	2.2	2.2				
		H		2.2	2.2	2.2	2.2	2.2	3.0				
070	7000	S		1.5	2.2	2.2	2.2	2.2	2.2				
		H		2.2	2.2	2.2	2.2	2.2	3.0				
800	8000	S				2.2	2.2	3.0	3.0	3.0	3.0		
		H				2.2	3.0	3.0	3.0	3.0	3.0		
100	10000	S			3.0	3.0	4.0	4.0	4.0	4.0			
		H			3.0	4.0	4.0	4.0	4.0	4.0			
120	12000	S			3.0	3.0	4.0	4.0	4.0	5.5			
		H			3.0	4.0	4.0	4.0	5.5	5.5			
150	15000	S				5.5	5.5	5.5	5.5	5.5	7.5		
		H				5.5	5.5	5.5	5.5	7.5	7.5		
210	21000	S				7.5	7.5	7.5	11.0	11.0	11.0		
		H				7.5	7.5	11.0	11.0	11.0	11.0		
240	24000	S				7.5	11.0	11.0	11.0	11.0			
		H				11.0	11.0	11.0	11.0	11.0			
270	27000	S				11.0	11.0	11.0	11.0	11.0			
		H				11.0	11.0	11.0	11.0	15.0			
300	30000	S					11.0	11.0	15.0	15.0	15.0		
		H					11.0	15.0	15.0	15.0	15.0		
330	33000	S					11.0	15.0	15.0	15.0	15.0	15.0	
		H					15.0	15.0	15.0	15.0	15.0	15.0	
350	35000	S					11.0	15.0	15.0	15.0	15.0	15.0	
		H					15.0	15.0	15.0	15.0	15.0	15.0	
400	40000	S						15.0	15.0	15.0	18.5	18.5	
		H						15.0	15.0	18.5	18.5	18.5	
450	45000	S							18.5	18.5	18.5	18.5	22.0
		H							18.5	18.5	18.5	22.0	22.0
500	50000	S								22.0	22.0	22.0	
		H								22.0	22.0		

Horizontal type standard unit IX

Mldel MKZS	Air flow (m³/h)	Motor power (kW) corresponding to external pressure (Pa)										
		270	320	370	420	470	520	570	620	670	720	
020	2000	0.55	0.75	0.75	0.75	0.75	1.1	1.1	1.1			
030	3000	0.75	1.1	1.1	1.1	1.1	1.1	1.5				
040	4000		1.1	1.1	1.5	1.5	1.5	2.2	2.2	2.2		
050	5000		1.5	1.5	1.5	1.5	2.2	2.2	2.2	2.2		
060	6000		2.2	2.2	2.2	2.2	2.2	3.0	3.0	3.0		
070	7000			2.2	2.2	2.2	2.2	3.0	3.0	3.0		
080	8000				2.2	3.0	3.0	3.0	3.0	3.0	4.0	
100	10000					4.0	4.0	4.0	4.0	5.5		
120	12000					4.0	4.0	5.5	5.5	5.5		
150	15000					5.5	5.5	5.5	7.5	7.5		
180	18000					7.5	7.5	7.5	7.5	7.5		
210	21000					7.5	11.0	11.0	11.0	11.0		
240	24000					11.0	11.0	11.0	11.0	11.0		

Horizontal type standard unit X

Mldel MKZS	Air flow (m³/h)	Motor power (kW) corresponding to external pressure (Pa)										
		290	340	390	440	490	540	590	640	690	740	790
020	2000	0.55	0.55	0.55	0.55	0.75						
030	3000		0.75	0.75	0.75	1.1						
040	4000		1.1	1.1	1.1	1.1	1.1					
050	5000		1.1	1.1	1.1	1.5	1.5	1.5	1.5			
060	6000		1.5	1.5	1.5	2.2	2.2	2.2	2.2			
070	7000		1.5	1.5	1.5	2.2	2.2	2.2	2.2			
080	8000			2.2	2.2	2.2	2.2	2.2	3.0	3.0		
100	10000			3.0	3.0	3.0	3.0	4.0	4.0			
120	12000			3.0	3.0	3.0	3.0	4.0	4.0			
150	15000			4.0	4.0	4.0	5.5	5.5	5.5	5.5		
180	18000			4.0	5.5	5.5	5.5	5.5	7.5	7.5		
210	21000			5.5	5.5	7.5	7.5	7.5	7.5	11.0		
240	24000			5.5	5.5	7.5	7.5	7.5	11.0	11.0		
270	27000			7.5	7.5	7.5	11.0	11.0	11.0	11.0	11.0	
300	30000				11.0	11.0	11.0	11.0	11.0	11.0	15.0	15.0

Humidification Performance and Specifications

Evaporative humidifier

Evaporative humidifier a type of hydrophilic material that can evenly distribute the water it absorbs on its surface to form a gasified layer of water. When air flows through the material surface, the water in the gasified layer is evaporated and gasified, and absorbed by the air. Based on this principle, the gasified humidifier is made. The thickness of wet film depends on the requirements for humidification volume. The water supply volume is three times the humidification volume.

Operation Conditions

Ambient temperature/ humidity	Humidifier body: 5-80°C; Under 90% RH
Critical wind speed	Less than 3.75 m/s
Water quality	Tap water, pure water
Water supply status	0.05-0.4MPa, 5-40°C
Water volume	2-3 times the humidification capacity, external water source connector size DN15 G1/2
Power supply	AC220V/50HZ

Specifications of unit with evaporative humidifier

Mdel MKZS	Air flow (m³/h)	Humidifier front dimensions		Maximum humidification (kg/h)							
		Height (mm)	Width (mm)	50mm	100mm	150mm	200mm	50mm	100mm	150mm	200mm
020	2000	452	650	5	11	14	16	3.5	5.9	8.2	10.6
030	3000	502	800	8	16	20	22	4.8	8	11.2	14.5
040	4000	544	900	9	19	24	26	5.9	9.8	13.7	17.6
050	5000	628	930	11	23	29	32	6.9	11.6	16.2	20.9
060	6000	628	1090	13	27	34	37	8	13.4	18.9	24.4
070	7000	751	1090	16	32	40	45	9.4	15.9	22.5	29
080	8000	751	1230	18	36	46	50	10.5	17.9	25.3	32.7
100	10000	904	1230	22	44	55	61	11.9	20.6	28.8	37.2
120	12000	904	1490	26	53	67	74	13.1	23.5	31.9	41.3
150	15000	954	1780	33	67	84	93	15	27.7	36.6	47.4
180	18000	1005	1980	39	79	99	109	16.5	31.2	40.5	52.4
210	21000	1107	2130	47	94	117	129	18.5	31.9	45.4	58.8
240	24000	1107	2440	54	108	135	148	20.3	35.1	49.9	64.7
270	27000	1208	2490	60	120	150	165	21.9	38	54	70
300	30000	1310	2490	65	130	163	179	23.3	40.3	57.4	74.4
330	33000	1361	2690	73	146	183	201	25.4	44	62.7	81.3
350	35000	1361	2850	77	155	193	213	26.6	46.1	65.6	85.1
400	40000	1501	2870	86	172	215	236	27.2	47.2	67.2	87.2
450	45000	1691	2870	97	194	242	266	27.2	47.2	67.2	87.2
500	50000	1858	2920	108	217	271	298	27.2	47.2	67.2	87.2
600	60000	2239	2870	128	257	321	353	27.2	47.2	67.2	87.2

Notes: When a evaporative humidifier equipped for the system, the internal resistance of the unit shall be increased correspondingly: 50mm-20Pa; 100mm-30Pa; 150mm-45Pa; 200mm-60Pa.

Selection software

In order to facilitate customers to determine their product needs, we provide a set of user-friendly selection software. The software pre-enters all the standard machine forms and parameters for commercial sets. Through the input of customer requirements of the parameters, you can quickly choose to meet the customer requirements of the model. After the type selection, the unit can also directly output the technical report, drawings, fan curve, table cooler calculation and quotation.

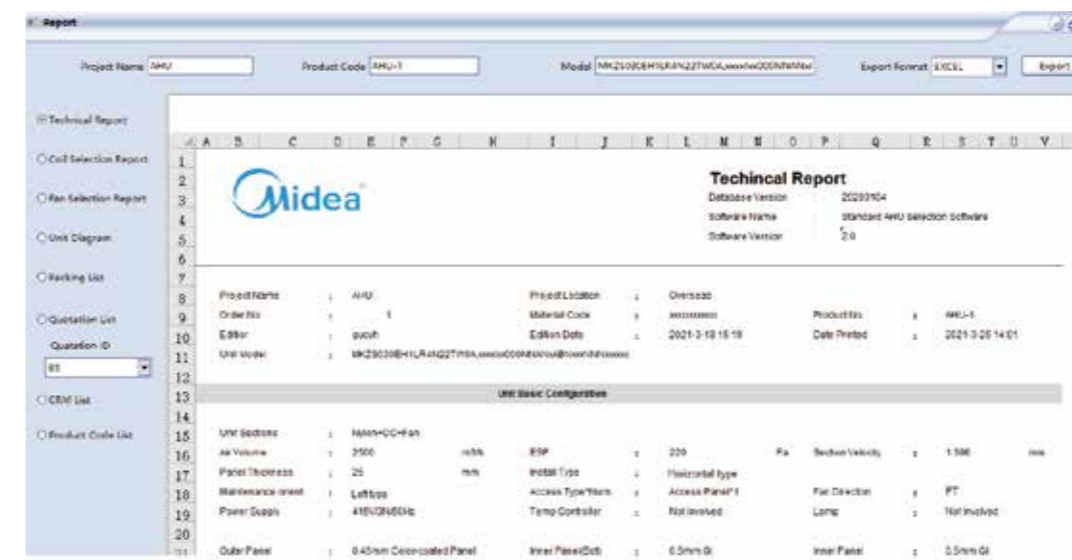
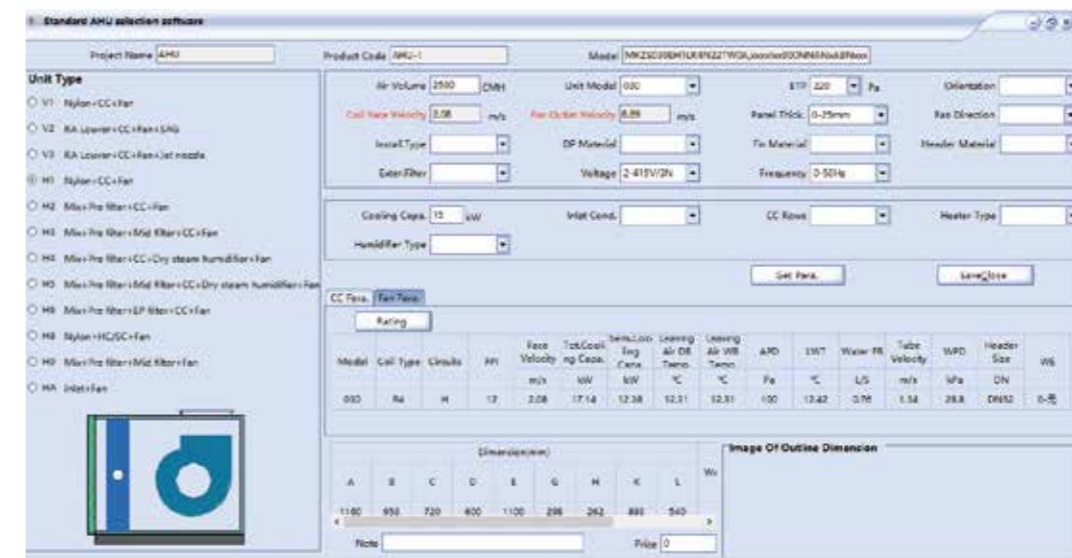
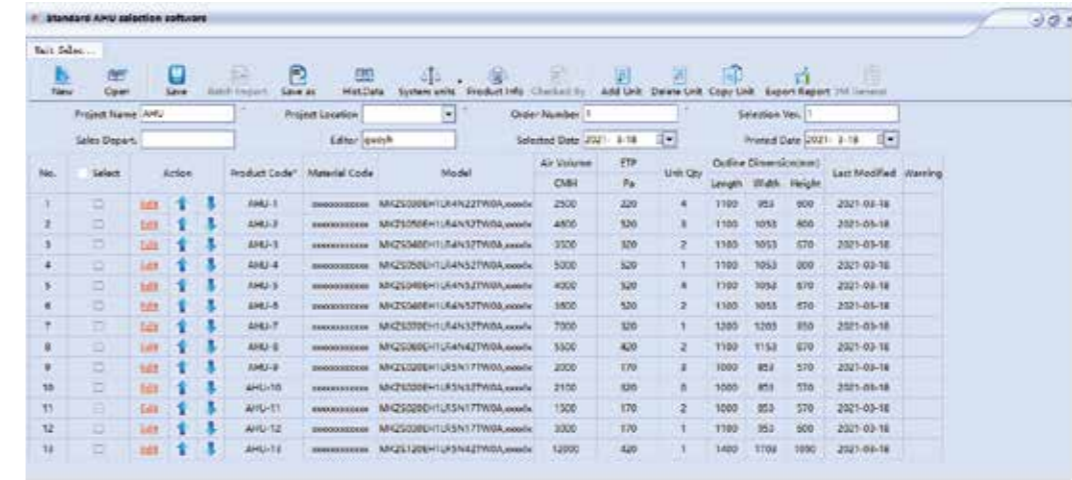

Unit installation

- Before unit installation, check whether the unit is damaged. If the unit is damaged or severely deformed, the unit panel or enclosure is severely scratched, or the fan or motor is loose, contact your dealer for repair or replacement.
 - To ensure safety, securely fix the unit when it is to be installed on the ceiling. Hoist the unit in the form as shown in the figure on the right, or use a forklift to move the unit. The hoisting point must be firm and strong enough to bear the weight of the unit and keep the unit horizontal.
 - Before wiring, check whether the voltage, frequency and phase of power supply comply with the unit specifications. The power voltage error must not exceed $\pm 10\%$ of the rated voltage. Before fan startup, rotate the fan impeller with hands to check whether there is sound of metal friction. If yes, resolve the problem first.
 - After power connection, start the fan. Check whether the impeller rotating direction is correct. If not, exchange the power-in phase.
- It is recommended to install the air plenum at the unit air inlet and outlet, install the adjusting valve at the air duct, and install the fire damper based on fire regulation requirements. If an electric air flow regulating valve is installed, the air valve actuator shall be started up before fan startup, and be shut down after fan shutdown.

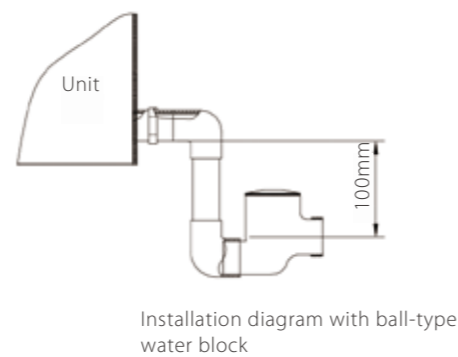
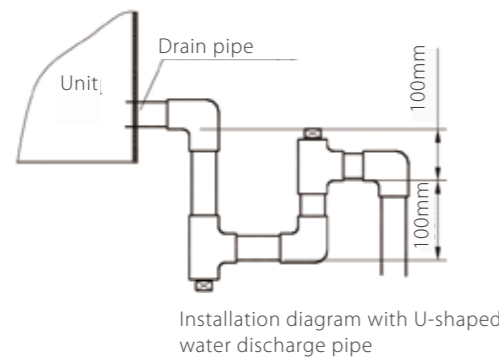
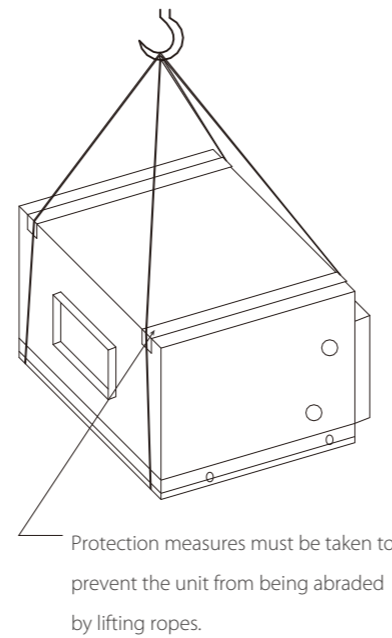

- Before water pipe connection, clean the water pipe. The cold (hot) water inlet/outlet direction shall comply with that indicated on the unit nameplate. Valves and filters must be installed on the unit water inlet/outlet pipe for flow regulation.
- During maintenance, cut off the cold (hot) water source and prevent foreign matters from entering the heat exchanger, as that may block the system. The water inlet/outlet pipe must be well insulated.
- During water inlet and outlet pipes connection, use a pipe wrench to fasten the water inlet and outlet pipes to avoid exerting torque to the pipes during operation. Use thread tape to seal the connectors to avoid water leakage. Water block must be installed to discharge condensate water generated by the system to the sewage piping through the drain pipe, as shown in the above figure.
- The weight of the air duct and water pipe cannot be borne by the unit.
- The unit must be reliably grounded. The electrical wire must comply with safety requirements.
- The unit shall be installed by professionals who are familiar with the product and under the relevant local regulations. Avoid collision, pressing and scratching during installation.

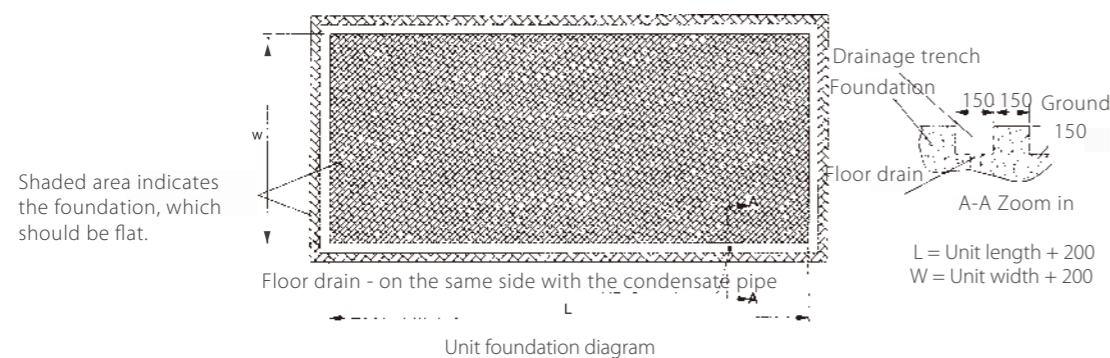

Installation Precautions

1. When the unit is not to be used for a long time and is to be left idle in winter, turn off the power.
2. To avoid electric shock, fire and other possible injuries, strictly follow these requirements:
3. Do not try to install or reconstruct the unit by yourself. Improper operation may lead to water leakage, electric shock, or fire.
4. Do not connect the ground line of the unit to a gas pipe, water pipe, or lightning rod.
5. Only accessories designated by Midea can be used. Users can apply for installation services or technical support from the manufacturer or authorized dealer.
6. Separate the unit controller data cable from the power supply cable to avoid interference.
7. Do not damage the power cable. Do not turn on/off the unit by plugging in/out the power cable.
8. Do not rinse the unit directly with water; otherwise, electric shock or other accidents may occur.
9. Do not try to repair the line yourself. Improper repair may lead to unit malfunction or damage.
To repair your unit, contact a local Midea company or an authorized servicing agency.
10. Do not use the unit in an environment with corrosive gases (such as acid, alkali, and salt mist); otherwise, the unit enclosure, pipeline or electrical component will be damaged.
11. Area around the unit should be clean, dry, and well ventilated. It is recommended to clean the air-side heat exchanger on a regular basis (once every 1~2 months) to maintain good heat exchange efficiency and save energy.
12. Regularly check whether the unit power and electrical system cables are secure and whether the electrical components are functional. In case of abnormalities, repair and replace in time. Regularly check whether the unit grounding is reliable.
13. Install the water discharge pipe as required in this manual. Keep the drainage smooth and arrange proper insulation to avoid the generation of condensate water. Check the water discharge pipe before unit operation. If the pipe is blocked, remove the foreign matters to ensure smooth drainage.
14. The minimum startup voltage of unit must be greater than 90% of the rated voltage. During unit operation, the voltage fluctuation should be within $\pm 10\%$ of the rated voltage, and the voltage difference between phases should be within $\pm 2\%$. Too high or too low voltage will adversely affect the unit performance. Make sure the power supply is stable. If the power supply is not stable, the overcurrent at the instance of unit startup can damage the unit motor.
15. Maintenance and repair can be performed only after the unit is turned off and the power supply is cut off.
16. For a faulty unit, do not start the unit until the fault is eliminated.
17. Do not short circuit the unit protector; otherwise, unit fault may occur.
18. Properly protect the cables inside the unit. Protect the insulation layer from being damaged by sharp objects.
19. Keep the wire cables away from heat sources. Do not move the wire cables if possible. Do not bend or twist the wire cables.
20. Air filter:

Regularly (recommended: twice a month) check the dust accumulation status of the unit filter. If a pressure difference detection device is installed, clean or replace the filter in time when the final resistance reaches the specified value.

Recommended final resistance:

Filtration efficiency specifications	Recommended final resistance (Pa)
G3 (primary efficiency)	100-200
G4 (primary efficiency)	150-250
M5-M6 (medium efficiency)	250-300

21. Heat exchanger:

Make sure that the coil fins and coppers have no scratches and dents. Keep the coil clean. Use a nylon brush to clean air pipe air pipe or nozzle to clean the coil. After cleaning, the coil external surface shall be free of dust, and the heat exchange efficiency of the internal surface shall be restored to the original level.

22. Re-adjust the belt tension after the unit has been running for a week to ensure a proper belt tension. Then, check the belt tension every three months.

23. Wire connectors will get loose after a certain period of unit running. Therefore, check and tighten (if required) the wire connectors three days after the initial running of unit.

24. Regularly check the fan and motor bearing (recommended: three times a month). Check the seal ring (such as V-seal ring) of motor bearing and replace it in time if required. Check if the connection gets loose. Check the vibration through abnormal sound monitoring. Check the bearing running status through oil usage or bearing vibration detection component monitoring. In case of any abnormality, stop the unit and perform troubleshooting. Heat or use special tools when installing or replacing the bearing. Do not knock or pry the bearing.

25. Fan bearing maintenance:

1) For a fan with lubricator fitting, lithium based grease grade

2 should be regularly added to the bearing.

2) Always use the same grade of grease.

3) The term of validity of grease depends on the grease type, bearing speed, shaft diameter and operating environment. In normal cases, grease should be replaced every 1500-hour fan running. If the fan is operating 7/24, replace grease every 500~700-hour fan running.

4) When filling grease, keep the shaft rotating. When a layer of fresh grease overflows from the dust-proof cover, stop filling, and rapidly rotate the wind wheel with hands to exhaust the redundant grease.

26. Check the seal ring of access door and the flexible connector of air duct regularly (recommended: once a month), and replace them when necessary.

27. Other precautions:

1) Clean the unit only after the unit is powered off and the power supply is turned off; otherwise, electric shock or other injuries may be caused.

2) Do not carry out maintenance when the unit is running.

3) Do not use steel wire or copper wire to replace the fuse. Use the fuse of proper specifications; otherwise, the unit will be damaged.

4) In case of any abnormalities (such as a burnt odor), turn off the power and contact your dealer. Continue using will damage the unit and may lead to electric shock or fire. Maintenance can be performed only by professional maintenance personnel. Be sure to turn off the power supply before wiring.

5) For more information, refer to the Installation and Operation Manual.

Note: The maintenance of unit components such as the humidifier, wheel heat recovery, burner, and spray shall be performed based on the relevant instructions or user manuals (if any).

Electrical Wiring Diagram

Control cabinet installation

When the motor power is not greater than 7.5 kW, the control panel is installed on the side or top of the MKZS UNIT. The motor wiring is completed. The thermostat is delivered with the unit, and is installed on the wall of the indoor operation room on site to achieve remote control. On-site wiring includes the power cable of the control panel and the signal cable between the thermostat and the control panel.

When the motor power is at least 11 kW, the motor adopts star-delta start. The control panel is delivered as an accessory separately, and its wiring needs to be completed on site, which includes the power cable of the control panel and the cable between the control panel and the motor. The motor power and thermostat are already installed on the control panel.

Other notes

Although a water valve can contribute to energy efficiency, to prevent freezing, it is strictly prohibited to install a water valve in all fresh air scenarios.

Water valve contact is applicable only to the switch type water valve that uses the 220V power supply, and cannot be used for adjusting valves.

